



HELLENIC ELECTRICITY DISTRIBUTION NETWORK OPERATOR S.A.

NOTICE OF CALL FOR TENDERS No ND-207

PROJECT: "Pilot Telemetry and Management System for the Electric Power Supply Demand by Residential and Small Commercial Consumers and Implementation of Smart Grids"

TECHNICAL SPECIFICATION

INSTALLATION BOXES OF SINGLE PHASE AND THREE PHASE "SMART" ELECTRONIC LOW VOLTAGE METERS

<p>SPECIFICATION HEDNO S.A.</p>	<p>INSTALLATION BOXES OF SINGLE PHASE AND THREE PHASE "SMART" ELECTRONIC LOW VOLTAGE METERS</p>	<p>ND/365/07.03.2013</p>
		
<p>Issued by the Metering Systems Section</p>	<p>Network Department</p>	

Contents

1. SCOPE	4
2. KEYWORDS	4
3. OPERATING CONDITIONS	4
3.1 GENERAL	4
3.2 OPERATING - STORAGE TEMPERATURE	4
3.3 HUMIDITY	5
3.4 TABLE OF CLIMATIC AND ENVIRONMENTAL CONDITIONS	5
4. NORMS/STANDARDS - SPECIFICATIONS	5
5. DESCRIPTION	7
5.1 GENERAL REQUIREMENTS - GENERAL CHARACTERISTICS	7
5.1.1. Materials	7
5.1.2. Manufacturing characteristics and finishing	8
5.1.3. Interchangeability	8
5.1.4. Safety requirements	8
5.1.5. Applicable drawings	9
5.1.6. Drawings and information to be submitted	9
5.1.7. Spare parts	9
5.1.8. Box Sample Submission	10
5.2. SPECIAL REQUIREMENTS AND CHARACTERISTICS	10
5.2.1. General	10
5.2.2. Special manufacturing characteristics	10
5.2.3. IP Degree of protection	13
5.2.4. Material	13
5.2.5. Accessories	13
6. TESTS	14
6.1. Design Tests	14
6.2. Type Tests	14
6.2.1. Type tests on raw material	14
6.2.2. Type tests on finished product	16
6.3. Sampling tests	19
6.3.1. Acceptance tests	19
6.3.2. Sampling	19
6.4. Series tests	20
7. SIGNS - MARKING	20
7.1 Signs	20
7.2. Marking	20
8. PACKING	21
9. APPENDICES	21
9.1. TABLES	21
9.2. DRAWINGS LIST	29

TECHNICAL SPECIFICATION HEDNO ND-365/07.03.2013 INSTALLATION BOXES OF SINGLE PHASE AND THREE-PHASE "SMART" ELECTRONIC LOW VOLTAGE METERS

1. SCOPE

This specification defines the manufacturing, tests, acceptance control and packing for transportation and delivery at HEDNO warehouses, of Polyester Boxes for housing single phase and three-phase "smart" Electronic Meters, which shall be used for the metering devices of Low Voltage supply customers.

2. KEYWORDS

Polyester Box for Meter Installation, Metering Device, Operating Voltage 230/400 V.

3. OPERATING CONDITIONS

3.1 GENERAL

The materials described in this specification shall be installed both outdoors (uncovered) and indoors.

They shall be mounted vertically on walls, concrete or wooden posts, or other similar structures.

Prior to their installation, the materials may be stored in storage areas of any type: outdoors (either shed or unshed) or indoors (without heating or air-conditioning).

The electronic meters that will be used for the metering will be electronic "smart" meters for connection to the L.V. network at which both the neutralization and the direct earth are applied.

The low voltage system operates with grounded neutral and the electric power is mainly supplied with a frequency of 50 Hz and voltage 230 / 400 V in the case of households and small to medium industrial and commercial consumers.

The voltage may vary between -10% and +10%.

At this voltage, the supply can be 3-phase or single-phase.

3.2 OPERATING - STORAGE TEMPERATURE

- The proper operation temperature zone for the boxes shall be between -25 °C and +55 °C.
- The storage and transport temperature zone shall be between -25°C and 70°C.

3.3 HUMIDITY

The boxes shall operate under average annual relative humidity greater than 75%.

Moreover, for thirty (30) days in total interspersed within the year, they shall operate under relative humidity 95%. Additionally, at random moments within the day, they shall operate under relative humidity 85%.

3.4 TABLE OF CLIMATIC AND ENVIRONMENTAL CONDITIONS

The climatic and environmental conditions under which the boxes shall be installed and continuously operate in a satisfactory manner are defined in the following table:

	2000 m
Maximum altitude	
Minimum ambient temperature	- 25° C
Average ambient temperature	20° C
Maximum ambient temperature	55° C
Maximum temperature at external surfaces due to solar radiation	70° C
Minimum relative humidity	5 %
Maximum relative humidity	95%

4. NORMS/STANDARDS - SPECIFICATIONS

The boxes and their accessories shall be industrial products manufactured and tested according to the European and International EN/IEC standards and to the Technical Specifications of HEDNO as mentioned below, which are valid on the day of bids submission.

The obtained degree of protection, the properties of the materials to be used for their manufacturing, and the final product shall comply with these standards.

All tests shall be carried out according to the IEN/IEC standards (unless specified otherwise) that are valid on the day of bids submission.

The standards applying to this specification are as follows:

ASTM D256orEN/ISO 180	Impact resistance of plastics and electrical insulating materials
ASTM D543 or ISO 175	Resistance of plastics to chemical reagents.
ASTM D570 or ISO 62	Water absorption of plastics
ASTM D638 or EN ISO 527-4	Tensile properties of plastics.
ASTM D 638-98	Standard Test Method for Tensile Properties of

	Plastics.
ASTM D790 or EN ISO 178	Flexural properties of unreinforced and reinforced plastics and electrical insulating materials.
ASTM D792 or ISO 1183	Density and specific gravity (relative density) of plastics by displacement.
ASTM D1525 or ISO 306	Vicat softening temperature of plastics.
EN / IEC 60068-2-2	Basic environmental testing procedures. Part 2 : Tests, Tests B : Dry heat.
EN / IEC 60068-2-11	Basic environmental testing procedures. Part 2 : Tests, Tests ka : Salt mist.
EN / IEC 60068-2-14	Basic environmental testing procedures. Part 2 : Tests, Tests N: Change of temperature.
EN / IEC 60068-2-30	Basic environmental testing Procedures. Part 2: Tests, Test Db : Damp heat cyclic.
EN / IEC 60216	Guide for the determination of thermal endurance properties of electrical insulating materials.
EN / IEC 60243	Recommended methods of test for electric strength of solid insulating materials at power frequencies.
EN / IEC 60529	Classification of degrees of protection provided by enclosures
IEC 60410	Sampling plans and procedures for inspection by attributes.
EN / IEC 60695-2-1	Fire hazard testing. Part 2 : Test methods, Glow wire test and guidance.
EN / IEC 60695-2-2	Fire hazard testing. Part 2 : Test methods, Needle flame test.
IEC 60707 or UL 94	Methods of test for the determination of the flammability of solid electrical insulating materials when exposed to an igniting source. Flammability testing.
ELOT EN 50102	Degrees of protection provided by enclosures for electrical equipment against external mechanical impacts (IK code).
ELOT EN 50298	Empty enclosures for low voltage switching and control device sets - General requirements.
PPC Specification X.K. 11.01/11.11.87	Electrolytic galvanization of iron or steel items.
PPC Specification X.K. 11.03/11.11.87	Chromium coating for galvanized surfaces.
PPC Specification X.K.	Electrolytic tinning.

11.04/23.10.92	
PPC Specification GR-88/7.9.83	Bolted connector with notch for copper conductors.
IEC 60999	Connecting devices – Safety requirements for screw-type and screwless-type clamping units for electrical copper conductors.

In cases where the requirements of this Specification contradict with the above versions of International Standards or any other relevant Standards, the HEDNO specification shall prevail.

The boxes shall have all required markings according to the European Standards; they are also required to have the "CE" certification mark at a visible spot on their base and cover, according to Ministerial Decree 470/85 (ONG issue 183/4.4.85) and 16717/5052/94 (ONG Issue 992/30.12.94).

Moreover, the box supplier shall submit a certificate from his factory, stating that it follows the procedures provided in ISO 9001 for manufacture items using polyester reinforced with glass fiber with the Compression Moulding (SMC) method as raw material, accompanied with a valid ISO 9001 certificate for the production plant of the polyester (SMC) to be used in the production of the boxes.

5. DESCRIPTION

This specification relates to the following items:

- Single-phase "smart" meter installation box.
- Three-phase "smart" meter installation box.

5.1 GENERAL REQUIREMENTS - GENERAL CHARACTERISTICS

5.1.1. Materials

All materials to be used for the manufacturing of the boxes shall be of very high quality, suitable for the specified purpose and operating conditions.

They shall be able to withstand the specified temperature and humidity without deformation or damage, and without compromising their mechanical and electrical properties beyond the specified limits.

The metallic parts that are susceptible to oxidization shall be effectively protected.

The protective coating to be used for this purpose shall not degrade under normal use or with the lapse of time under the specified operating conditions, thus losing its protective properties.

All non-metallic parts shall be made of non-hygroscopic material and shall provide protection against fire and propagation of flames that might occur internally or close to the material; they shall also comply with the requirements of EN/IEC 60707 standards, level FH 1 or UL 94 for class VO.

5.1.2. Manufacturing characteristics and finishing

The meter boxes shall be manufactured in a manner that provides strength and reliability, offers satisfactory mechanical protection against impacts and pressure and facilitates mounting of the box and installation of the meter, of the micro circuit-breaker of rail and conductors.

All surfaces shall be free of defects, smooth and shiny.

The polyester material to be used for the boxes in question shall be reinforced with glass fiber type SMC and shall be of light gray color, similar to the color that HEDNO uses for such boxes to date.

As electronic devices shall be housed in them (meter, equipped with load switch and communication device), the boxes to be manufactured shall comply with the specified increased water-tightness level.

In order to achieve the specified water-tightness a suitable rubber gasket shall not be used between the box base and cover.

All boxes shall provide sufficient ventilation in order to avoid condensation and to limit rise of temperature in their interior.

Ventilation shall be ensured by providing a suitable gap of 2-3 mm between the base and the cover according to the attached drawings.

The meter boxes shall be manufactured in a manner that ensures continuous supply of power, provides strength and reliability, offers satisfactory mechanical protection against impacts and pressure and facilitates mounting.

5.1.3. Interchangeability

All parts comprising the box shall be fully interchangeable.

When used with a metering device, the assembled single-phase and three-phase boxes shall be fully interchangeable (the same external dimensions) with the boxes complying with the older HEDNO Specifications GR-226 A and GR-226 B.

5.1.4. Safety requirements

The boxes shall be properly manufactured in order to provide, when installed, full protection against contact strains.

The external enclosure edges shall be rounded in order to avoid injuries.

Due to the use of glass fiber in the polyester material, perforation or drilling of the material shall be generally avoided.

For this purpose, suitable removable circular parts for cable routing (knock-outs) shall be provided at the box base, which shall be visible on the outer side of the base.

The removal of such parts shall be easy and for this purpose the wall thickness at those points shall be very small.

5.1.5. Applicable drawings

Apart from the general and special requirements, the material shall comply, regarding its basic dimensions, with the drawings attached to the drawings list 9.2 in the Appendix.

These drawings shall be considered as manufacture drawings, and shall be used as a guide for the final manufacturing.

5.1.6. Drawings and information to be submitted

The bid shall be submitted together with a complete technical description addressing all requirements of this specification one-by-one, and detailed drawings showing in general the manufacturing of the material, its finishing and the materials from which it shall be manufactured.

The bids shall necessarily be accompanied with certificates for all suitability tests (both for the polyester raw materials and for the boxes) related to materials used for the manufacturing of the boxes, as specified in paragraph 6.2, which shall clearly show that the requirements of the specifications are met.

For each item under bid, the supplier is required to inform us about the properties and characteristics of the materials he uses for their manufacturing, and for this purpose he shall fill in and submit, together with its bid, Tables 9.1.2 and 9.1.4 (in the Appendix), replacing asterisks with the properties of the material.

The supplier is also required to submit, together with his bid, complete manufacture drawings in which all details of the boxes shall be thoroughly presented.

5.1.7. Spare parts

The suppliers shall ensure the availability of spare parts and accessories for a period of 10 years following the date of the last partial delivery of the material.

5.1.8. Box Sample Submission

The bids shall be accompanied, on penalty of rejection, with a sample of a finished box identical to those specified.

The above sample shall be submitted to the technical service of ND/ /Metering Systems Section, for evaluation.

The lowest bidder/s of the Firm is/are required to submit to our Service, prior to series production, complete samples for final approval.

The period intervening from the signing of the Contract until the sample submission from the Supplier shall in no case exceed one month and in case the Supplier is obliged to make corrections and submit a new sample, the deadline shall not exceed one month following the date of rejection of the initial sample.

In case of failure of the new sample to meet the requirements of the technical specification, the said Contract shall be terminated.

5.2. SPECIAL REQUIREMENTS AND CHARACTERISTICS

5.2.1. General

This paragraph includes the special requirements and the specific characteristics of the boxes and their accompanying accessories.

Moreover, the boxes shall comply with the drawings attached to the drawings list 9.2 regarding the following:

- Design - Form
- Basic dimensions
- Locations of holes and inserts for mounting screws
- Markings
- Installation in array
- Provision of notches for easy detachment of enclosure parts
- Installation protection against water penetration
- Sufficient ventilation.

5.2.2. Special manufacturing characteristics

The box shall be manufactured with the Compression Moulding method, and shall be entirely made of high quality thermoset material, polyester type SMC in particular, reinforced with glass fiber.

The quantitative requirements regarding the properties of the glass fiber reinforced polyester to be used for the manufacturing of the box and for the boxes themselves are described in the attached Table 9.1.1 in the Appendix.

Morphologically, the box dimensions shall comply with the attached drawings of list 9.2.

- Base (1 piece + 1 Connection terminal+ 1 support rail with 2 screws).
- Cover (1 piece + 1 safety screw)
- Basic accessories (1 full set)

The single-phase or three-phase electronic meter box shall be able to accommodate one single-phase or three-phase meter which shall be mounted with screws to the sockets of the box base which are used for the meter mounting and have bronze insert nuts of appropriate size, as well as one single-pole or three-pole micro circuit-breaker and an appropriate terminal block for connection of the incoming and outgoing earth-neutral cables.

The earth-neutral terminal blocks shall be made of tinned bronze according to PPC Specification X.K. 11.01/11.11.87.

Tinning shall be carried out according to PPC Technical Specification X.K. 11.04/23.10.92, with a thickness of at least 15 µm.

The terminals shall be suitable for tightening bundle- or single-core cables with cross-section between 6 and 16 mm², using cable connectors.

The details for the terminals are given in the attached drawing list 9.2.

A window for taking meter readings shall be provided at the upper part of the box cover.

The clear window of box cover for taking meter readings shall be made of polycarbonate material in accordance with the attached drawings of the appendix.

In case of breaking, the window shall be easily replaced with a new interchangeable window.

For this purpose suitable holes shall be provided on the box cover, enabling easy installation and replacement of the window, as well as suitable grooves for sealing the window, as shown in the attached drawings.

The quantitative requirements regarding the properties of the polycarbonate to be used for the manufacturing of the window for taking meter readings are described in the attached Table 9.1.3 in the Appendix.

At the lower part of the cover a sliding door shall be installed, enabling access to the micro circuit-breaker and easy rearmouring of the circuit-breaker.

The access door shall be lockable using a small lock.

When this door opens, it enables manual armouring of the micro circuit-breaker.

The clear plastic cover of the micro circuit-breaker operating recess shall "snap" on closing in order to avoid its falling down if the customer has not secured it with a small lock.

The material of the door shall be the same as the window for taking the meter readings, i.e. polycarbonate, and its dimensions are given in the attached drawings.

Attached to the inner part of the cover shall be the access funnel (cup) for manual arming of the micro circuit-breaker button, which shall be made of special plastic material.

The micro circuit-breaker access funnel shall be made of suitable self-quenching plastic material, with flammability index FH1 according to standards EN/IEC 60707 or VO according to the standard.

The access funnel shall be fitted on the box cover with special glue, which, however, shall not obstruct the easy sliding of the access door.

The properties of the plastic material, the funnel dimensions and its fitting location on the cover are given in the attached drawings and in table 9.1.5.

The detachable box cover shall fit on the box base and shall be secured with a (safety) screw, with dimensions as shown in the attached drawings.

The screw shall be made of tinned bronze and it shall have a suitable hole on its head for the sealing wire.

The box shall be sealed with a special safety seal in order to prevent any illegal access to the internal of the box as well as any access from non-authorized persons, and to ensure protection against contact with live elements inside the box.

The HEDNO relief mark and the mounting holes for the Customer Note shall be on the surface of the box cover at the locations specified in the drawings attached in Appendix 9.2.

All bronze or copper items to be used shall be tinned according to Specification X.K. 11.04/23.10.92, and all metallic items shall be galvanized according to Specification X.K. 11.01, with average galvanization thickness 25 µm and chromium strength treatment of 96 h in salt mist according to Specification X.K. 11.03.

Bronze insert nuts of appropriate size shall be installed (built-in during casting of the polyester material) in all sockets of the box base used for mounting the meter according to DIN 16903.

The number of insert nuts and their installation positions on the box base are shown in the attached drawings of drawings list 9.2.

The support rail of the micro circuit-breaker shall be metallic and shall have two holes for its mounting on the box base, and it shall also have stops at its upper and lower ends to prevent sliding of the circuit-breaker.

The boxes shall be delivered with all accessories packed.

5.2.3. IP Degree of protection

The boxes shall be provided with a degree of protection equal at least to IP 44 according to the regulations EN/IEC 60529.

All boxes shall bear at a prominent place a "CE" marking in accordance with those referred to in the Ministerial Resolutions 470/85 (ONG Issue 183/4.4.85) and 16717/5052/94 (ONG Issue 992/30.12.94).

5.2.4. Material

The meter boxes shall be manufactured with the Compression Moulding method, and they shall be made of high quality thermoset material (polyester reinforced with glass fiber, type SMC).

The final composition of the polyester material to be selected for the manufacturing of the boxes shall ensure the operating characteristics and shall comply with the special requirements for the installation of electrical equipment.

Thus, the boxes shall provide:

- Improved insulating capability
- High mechanical strength against impact and pressure
- Proper rigidity
- High resistance to chemicals, common solvents and ultraviolet radiation
- Low water absorption
- Resistance to aging (no change in dimensions and no deformation of the box)
- High operating temperature limit
- Resistance to heat and fire

The quantitative requirements regarding the above properties of the polyester materials that shall be used for the manufacturing of the boxes are given in Table 9.1.1, Appendix 9.

5.2.5. Accessories

Each box shall be delivered complete, with its cover, its base and the appropriate earth connection terminal mounted at its position and in one small plastic bag inside the box.

The small plastic bag shall contain all necessary screws for mounting the meter on the box base, the screws for the earth terminal, the screw for the box cover and the corresponding support rail for the micro circuit-breaker with its mounting screws.

6. TESTS

The manufacturer shall perform tests (according to specifications/standards or international standards listed in Table 9.1.1 of the Appendix) in order to establish that the material under bid (SMC) has the properties specified in Table 9.1.1 in the Appendix.

These tests may be repeated either partially or in total during the series production phase, at the discretion of the Supervision and at the Corporation's expenses.

In case of material failure the cost shall be borne by the supplier.

If it is ascertained that the material composition has been modified during the production phase, new tests shall be performed.

6.1. Design Tests

Not provided.

6.2. Type Tests

The bids shall necessarily be accompanied with certificates for all type tests performed which are related to the raw material (polyester) and to a finished box, which shall clearly show that the requirements of the specification are met.

Tests shall be conducted either in line with standards/specifications listed in Table 9.1.1 of the Appendix or with equivalent international specifications.

All certificates issued by Testing, Research and Standards Centre (KDEP) or other accredited by independent private or public bodies laboratories specialized in plastic material tests shall be accepted.

Any bids not accompanied by the above certificates shall be rejected during the technical evaluation stage.

During the delivery stage of the first lot of each item, any type test may be performed at the supervision's discretion.

6.2.1. Type tests on raw material

6.2.1.1. Determination of impact breaking strength of the plastic materials used for the manufacturing of the boxes.

The test shall be performed Εμφάνιση επιφάνειας εργασίας.scf according to Standards ASTM D256 (or EN/ISO 180) "Impact resistance of plastics and electrical insulating materials".

6.2.1.2. Determination of tensile breaking strength of the plastic materials used for the manufacturing of the boxes.

The test shall be performed according to Standards ASTM D638 (or EN/ISO D527-4) "Tensile properties of plastics".

6.2.1.3. Determination of flexural yield strength of the plastic materials used for the manufacturing of the boxes.

The test shall be performed according to Standards ASTM D790 (or EN/ISO 178) "Flexural properties of unreinforced and reinforced plastics and electrical insulating materials".

6.2.1.4. Determination of density of the plastic materials used for the manufacturing of the boxes.

The test shall be performed according to Standards ASTM D792 (or EN/ISO 1183) "Density and Specific Gravity (Relative Density) of plastics by displacement".

6.2.1.5. Determination of the softening temperature of the plastic materials used for the manufacturing of the boxes.

The test shall be performed according to Standards ASTM D1525 (or EN/ISO 306) "Vicat softening temperature of plastics".

6.2.1.6. Determination of water absorption by the plastic materials used for the manufacturing of the boxes.

The test shall be performed according to Standards ASTM D570 (or EN/ISO 62) "Water absorption of plastics".

6.2.1.7. Test for confirmation of the resistance of the plastic materials used for the manufacturing of the boxes to acidic or alkaline chemical reagents and common solvents.

The test shall be performed according to Standards ASTM D543 (or EN/ISO 175) "Resistance of plastics to chemical reagents". The chemical reagents used for this test shall be those mentioned in paragraphs 5.3.5, 5.3.7, 5.3.8, 5.3.23, 5.3.28, 5.3.33, 5.3.42, 5.3.47, 5.3.50 of the relevant ASTM standards.

6.2.1.8. Determination of flammability level of the plastic materials used for the manufacturing of the boxes.

The test shall be performed as described in Standards EN/IEC 60707 "Methods of test for the determination of the flammability

of solid electrical insulating materials when exposed to an igniting source"

Any other test, which may be considered as necessary in order to examine in detail any special problems that may either occur during the acceptance tests or be experienced during the use of the material.

6.2.2. Type tests on finished product

All tests described below are considered as type tests. Note that these tests (either all or a certain number of them) shall be performed in the following order:

6.2.2.1. Confirmation of suitability of the boxes for use or storage under high temperature conditions.

The test shall be performed as described in Standards EN/IEC 60068-2-2 "Basic environmental testing procedures - Part 2: Tests - Test Bd: Dry heat".

The test shall be considered successful if no deformation of fault occurs either during or after the test, which might limit the functionality of the materials.

Moreover, following the recovery period, the plastic boxes shall successfully pass the impact test as described in paragraph 6.2.1.1.

6.2.2.2. Test for the impact of temperature change on the boxes.

The test shall be performed as described in Standards EN/IEC 60068-2-14 "Basic environmental testing procedures - Part 2: Tests - Test Nb: Change of temperature with specified rate of change".

The test shall be considered as successful if no deformation of fault occurs either during or following the test, which might limit the functionality of the materials.

Moreover, following the recovery period, the plastic boxes shall successfully pass the impact test as described in paragraph 6.2.1.1.

6.2.2.3. Test for the confirmation of protection level against external mechanical impacts (IK code).

This test shall be performed as described in Standards ELOT EN 50102, for protection level IK 10.

The impact energy shall be 20 Joules.

The test shall be performed at any point on the flat surface of the box (fully assembled with its cover in place).

The test shall be performed as described in paragraph 6.4. of the abovementioned standard EN 50102.

The test shall be considered successful if no indication of fault occurs, which might limit the functionality of the box.

Any slight deformation, which however does not reduce the protection against penetration of solid objects, dust or water, shall be accepted.

6.2.2.4. Test for protection against humidity and oxidation.

This test includes the following individual tests:

a. Humidity - temperature test.

The test shall be performed as described in Standards EN/IEC 60068-2-30: "Basic environmental testing procedure - Part 2 : Tests - Test Db and guidance: Damp heat cyclic, 12 + 12 hour cycle".

The boxes to be tested shall be mounted on a flat vertical surface with all screws provided by the manufacturer for this purpose. The test shall be performed on fully assembled boxes, with all metallic parts in place and their covers closed.

The test shall be considered successful if:

- following the test, there is no indication of deformation, cracking or other fault on the plastic parts, which might limit their functionality.
- there is no indication of oxidation on metallic parts.

Moreover, following the recovery period, the boxes shall successfully pass the impact test (paragraph 6.2.1.1) and the dielectric breakdown voltage test as described in paragraph 6.2.2.6.

b. Salt mist test (for metallic parts)

The test shall be performed as described in Standards EN/IEC 60068-2-11: "Basic environmental testing procedure - Part 2 : Tests - Test Ka : Salt mist".

This test is performed in order to control the metallic components at the box base as well as at its door, so it must be performed with the door open.

The test shall be considered successful if no indication of oxidation occurs on the metallic parts.

6.2.2.5. Test for protection against penetration of solid objects and water.

The boxes shall be mounted on a flat vertical surface with all screws provided by the manufacturer for this purpose. These tests shall be performed on fully assembled boxes, with their metallic parts in place and their cover and access door closed, for protection degree IP 43, according to Standard EN/IEC 60529.

These tests consist of the following individual tests:

a. Protection against penetration of solid objects and dust.

The test shall be performed as described in EN/IEC 60529 "Classification of degrees of protection provided by enclosures".

b. Protection against water penetration.

The test shall be performed as described in EN/IEC 60529 according to the required degree of protection.

6.2.2.6. Dielectric test

This test shall be performed as described in EN/IEC 60243 "Recommended methods of test for the electric strength of solid insulating materials at power frequencies".

- The voltage rise rate shall be 1kV/sec (test on polyester raw material).
- Using a voltage of 4 kV for 1 min (test on finished box).

6.2.2.7. Tests for resistance to heat and fire

The following tests shall be performed on the plastic parts of the box:

a. Glow wire test

The test shall be performed as described in EN/IEC 60695-2-1 "Fire hazard testing - Part 2: Test methods - Glow wire test and guidance".

b. Needle flame test

The test shall be performed as described in EN/IEC 60695-2-2: "Fire hazard testing - Part 2 : Test methods - Needle flame test".

The test burner flame shall be placed exactly as shown in figure 1.c of the relevant IEC standard.

6.2.2.8. Confirmation of compliance of the box dimensions with the approved manufacture drawings.

6.3. Sampling tests

6.3.1. Acceptance tests

The acceptance tests are as follows:

a. Visual control

The boxes shall be visually controlled in order to confirm that:

- There is no trace of damage or deformation at any point
- The outer surfaces are smooth and free of defects
- There are no indications of faulty casting
- Marking is correct and complies with the requirements of the specification
- All accessories are included

b. Confirmation of interchangeability on pieces of the same type.

c. Performance of the tests of paragraphs 6.2.2.2, 6.2.2.9, 6.2.2.3, 6.2.2.5, 6.2.2.6, 6.2.2.7.

6.3.2. Sampling

The above acceptance tests shall be performed on a randomly selected sample from the lot to be received, according to EN/IEC 60410 with the following criteria:

- Control level II (table I, IEC 410).
- Simple or double sampling plans (tables II and III, IEC 410).
- Acceptable quality level AQL = 1.0, for each separate test.

In the case of failure on some acceptance tests that entails the rejection of the lot or in case of bad experience from previous use of the material, it

is required to perform those suitability tests that are related to the failure or bad experience.

In this case the suitability tests shall be performed on three plastic boxes randomly selected from the next lot, prior to its acceptance.

In case one of the plastic boxes from the sample of three fails, even in one point of a single test, the suitability tests shall be repeated on a sample of two boxes.

In case a second failure occurs, the lot shall be rejected.

It must be noted that the lots coincide with the partial deliveries of the material.

6.4. Series tests

Not provided for.

7. SIGNS - MARKING

7.1 Signs

No signs are provided for.

7.2. Marking

Each box shall have the following relief or engraved indications at a visible point (at the base or the door), which shall be designated by HEDNO:

- The HEDNO logo
- The Contract number and the lot index number
- The manufacturer's Name or logo
- The HEDNO material code number

The exact dimensions of all markings and their exact positions are specified in drawings 9.2. in the appendix.

According to paragraph 5.2.1 of the Specification, the above material shall have the following numbers (relief or engraved) at a suitable position so that the proper fitting and water-tightness of the box is not affected:

HEDNO MATERIAL CODE

K.Y. 454001631 on single-phase boxes,

K.Y. 454002131 on three-phase boxes.

8. PACKING

Boxes shall be delivered fully assembled.

Each box shall be carefully packed in a plastic bag and then inside EU pallets and the total weight of each pallet shall not exceed 550 kg.

These boxes shall be externally and indelibly marked with the Contract number, the material Code, the Manufacturer's Data.

Using the above packing, it shall be also possible to store the boxes at open spaces without additional protection against weather conditions (rain or moisture).

9. APPENDICES

9.1. TABLES

TABLE 9.1.1 - MATERIAL PROPERTIES AND QUANTITIES FOR ITS TESTS (polyester reinforced with glass fiber of SMC type)

Index	Characteristic or test	Specification paragraph	Standard	Units	Values
1	Impact breaking strength (Reversed Notch Izod)	6.2.1.1	ASTM D256 ή EN ISO 180	ft * lbf ----- --- in. of Width KJ/m ²	= 11 > 50
2	Tensile breaking strength	6.2.1.2	ASTM D638 ή EN ISO 527-4	P.S.I. Mpa	min. 9.000 min 61
3	Flexural yield strength	6.2.1.3	ASTM D790 ή EN ISO 178	P.S.I. Mpa	min. 20.000 min 138
4	Density	6.2.1.4	ASTM D792 ή ISO 1183	gr/cm ³	1,7-1,8
5	Thermal strength (Softening) Vicat (Method B)	6.2.1.5	ASTM D1525 ή ISO 306	°C	130
6	Water absorption 24h/23°C	6.2.1.6	ASTM D570 ή ISO 62	%	0,5
7	Impact of solvents and chemical reagents	6.2.1.7	ASTM D543 ή ISO 175	-	Καμιά επίδραση στην λειτουργικότητα
8	Material flammability	6.2.1.8	IEC 60707 ή UL 94	Βαθμός Κλάση	FH 1 V0
9	Test in hot and dry environment (Bd Test)	6.2.2.1	EN / IEC 60068-2-2	°C - hrs	100-16
	Temperature				

10	variation test (Nb Test)	6.2.2.2	EN / IEC 60068-2-14	°C	min. -25 max. +75
11	Level of protection against impact (IK code)	6.2.2.3	EN 50102	Βαθμός	IK 10
12a	Test in hot and wet environment (Bd Test) Variation 1	6.2.2.4.α	EN / IEC 60068-2-30	°C - κύκλοι	55 – 8
12b	Salt mist test (Ka Test)	6.2.2.4.β	EN / IEC 60068-2-11	εβδομάδες	2
13	Level of Protection	6.2.2.5	EN / IEC 60529	--	IP 44
14	Dielectric strength	6.2.2.6	EN / IEC 60243	KV / mm	min 12
15a	Glow wire test	6.2.2.7.α	EN / IEC 60695-2-1	°C	960
15b	Needle flame test	6.2.2.7.β	EN / IEC 60695-2-2	Sec	30

TABLE 9.1.2 - MATERIAL REQUIREMENTS AND QUANTITIES FOR ITS TESTS (polyester reinforced with glass fiber of SMC type)

(TO BE FILLED-IN BY THE SUPPLIER)

Index	Characteristic or test	Specification paragraph	Standard	Units	Values
1	Impact breaking strength (Reversed Notch Izod)	6.2.1.1	ASTM D256 ñ EN ISO 180	ft * lbf ----- ----- in. of Width KJ/m²	*
2	Tensile breaking strength	6.2.1.2	ASTM D638 ñ EN ISO 527-4	P.S.I. Mpa	*
3	Flexural yield strength	6.2.1.3	ASTM D790 ñ EN ISO 178	P.S.I. Mpa	*
4	Density	6.2.1.4	ASTM D792 ñ ISO 1183	gr/cm³	*
5	Thermal strength (Softening) Vicat (Method B)	6.2.1.5	ASTM D1525 ñ ISO 306	°C	*
6	Water absorption 24h/23°C	6.2.1.6	ASTM D570 ñ ISO 62	%	*
7	Impact of solvents and chemical reagents	6.2.1.7	ASTM D543 ñ ISO 175	-	*
8	Material flammability	6.2.1.8	IEC 60707 ñ UL 94	Level Class	*
	Test in hot and				

9	dry environment (Bd Test)	6.2.2.1	EN / IEC 60068-2-2	°C - hrs	*
10	Temperature variation test (Nb Test)	6.2.2.2	EN / IEC 60068-2-14	°C	*
11	Level of protection against impact (IK code)	6.2.2.3	EN 50102	Level	*
12a	Test in hot and wet environment (Bd Test) Variation 1	6.2.2.4.α	EN / IEC 60068-2-30	°C - CYCLE S	*
12b	Salt mist test (Ka Test)	6.2.2.4.β	EN / IEC 60068-2-11	weeks	*
13	Level of Protection	6.2.2.5	EN / IEC 60529	--	*
14	Dielectric strength	6.2.2.6	EN / IEC 60243	KV / mm	*
15a	Glow wire test	6.2.2.7.α	EN / IEC 60695-2-1	°C	*
15b	Needle flame test	6.2.2.7.β	EN / IEC 60695-2-2	Sec	*

TABLE 9.1.3 - MATERIAL PROPERTIES AND QUANTITIES FOR ITS TESTS (Polycarbonate – Readings window & Access door)

Index	Characteristic or test	Specification paragraph	Standard	Units	Values
1	Impact breaking strength (Izod notched Impact strength at 23 °C, 3.2 mm wall section)	6.2.1.1	ASTM D256	KJ /m²	> 20
2	Dielectric strength	6.2.2.6	IEC 243	KV / mm	Min 12
3	Material flammability	6.2.1.9	IEC 707 'H' UL 94	Level 'H' Class (mm)	FH 1 'H' V-2 , 3mm
	<u>Special characteristics:</u>				
1	Clear (Visual Control)				Remains functional
2	Stable under UV radiation				Remains functional
3	Stable under weather conditions				Remains functional

TABLE 9.1.4 - MATERIAL REQUIREMENTS AND QUANTITIES FOR ITS TESTS (Polycarbonate – Readings window & MCB door)

(TO BE FILLED-IN BY THE SUPPLIER)

Index	Characteristic or test	Specification paragraph	Standard	Units	Values
1	Impact breaking strength (Izod notched Impact strength at 23 °C, 3.2 mm wall section)	6.2.1.1	ASTM D256	KJ /m²	*
2	Dielectric strength	6.2.2.6	IEC 243	KV / mm	*
3	Material flammability	6.2.1.9	IEC 707 'H' UL 94	Level 'H' Class (mm)	*
	<u>Special characteristics</u> :				
1	Clear (Visual Control)				*
2	Stable under UV radiation				*
3	Stable under weather conditions				*

TABLE 9.1.5 - MATERIAL PROPERTIES AND QUANTITIES FOR ITS TESTS (Plastic access funnel)

Index	Characteristic or test	Specification paragraph	Standard	Units	Values
1	Dielectric strength	4.3.1.6	EN/IEC 243	kV / mm	Min 12
2	Material flammability	4.2.1.11	EN/IEC 60707 ñ UL 94	Level	FH 1

TABLE 9.1.6 - MATERIAL REQUIREMENTS AND QUANTITIES FOR ITS TESTS (Plastic access funnel)

(TO BE FILLED-IN BY THE SUPPLIER)

Index	Characteristic or test	Specification paragraph	Standard	Units	Values
1	Dielectric strength	4.3.1.6	EN/IEC 243	kV / mm	*
2	Material flammability	4.2.1.11	EN/IEC 60707 ñ UL 94	Level	*

9.2. DRAWINGS LIST

9.2.1. Drawings for single-phase boxes:

Full box Drawing no
Three dimension view2.1.

Box base Drawing no

- Base underneath view 2.1.1.
- Base plan view 2.1.2.
- Base section A-A 2.1.3.
- Base section B-B..... 2.1.4.
- Base right side view 2.1.5.

Box door Drawing no

- Cover plan view 2.2.1.
- Cover underneath view..... 2.2.2.
- Cover section A-A 2.2.3.
- Cover section B-B 2.2.4.
- Cover left side view 2.2.5.

Readings window Drawing no

- Window plan view 2.3.1.
- Window underneath view 2.3.2.
- Window section A-A 2.3.3.
- Window section B-B 2.3.4.
- Window left side view 2.3.5.

Access door and funnel (cup) for the MCB.... Drawing no

- Door.....2.4.1.
- Funnel2.4.2.

Earth-neutral connection terminal..... Drawing no

- Earth terminal..... 2.5.1.
- Safety screw2.5.2.

9.2.2. Drawings for three-phase boxes

Full box..... Drawing no
Three dimension view3.1.

Box base Drawing no

- Base underneath view 3.1.1.
- Base plan view 3.1.2.
- Base section A-A..... 3.1.3.

- **Base section B-B..... 3.1.4.**
- **Base right side view 3.1.5.**

Box door Drawing no

- **Cover plan view 3.2.1.**
- **Cover underneath view..... 3.2.2.**
- **Cover section A-A 2.2.3.**
- **Cover section B-B 3.2.4.**
- **Cover left side view 3.2.5.**

Readings window Drawing no

- **Window plan view 3.3.1.**
- **Window underneath view 3.3.2.**
- **Window section A-A 3.3.3.**
- **Window section B-B 3.3.4.**
- **Window left side view 3.3.5.**

Access door and funnel (cup) for the MCB...Drawing no

- **Door..... 3.4.1.**
- **Funnel 3.4.2.**

Earth-neutral connection terminal.....Drawing no

- **Earth terminal..... 3.5.1.**
- **Safety screw..... 3.5.2.**

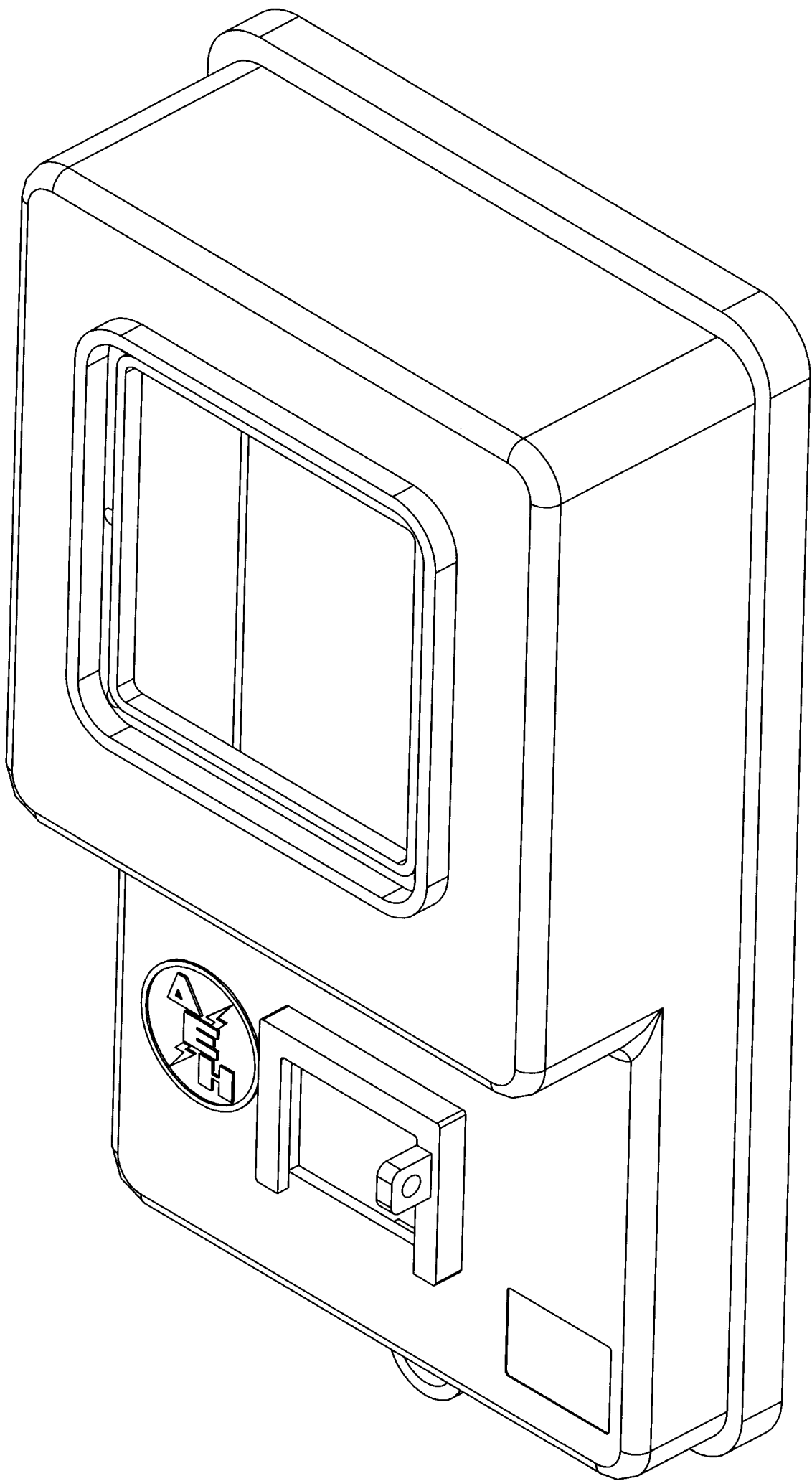

1φ

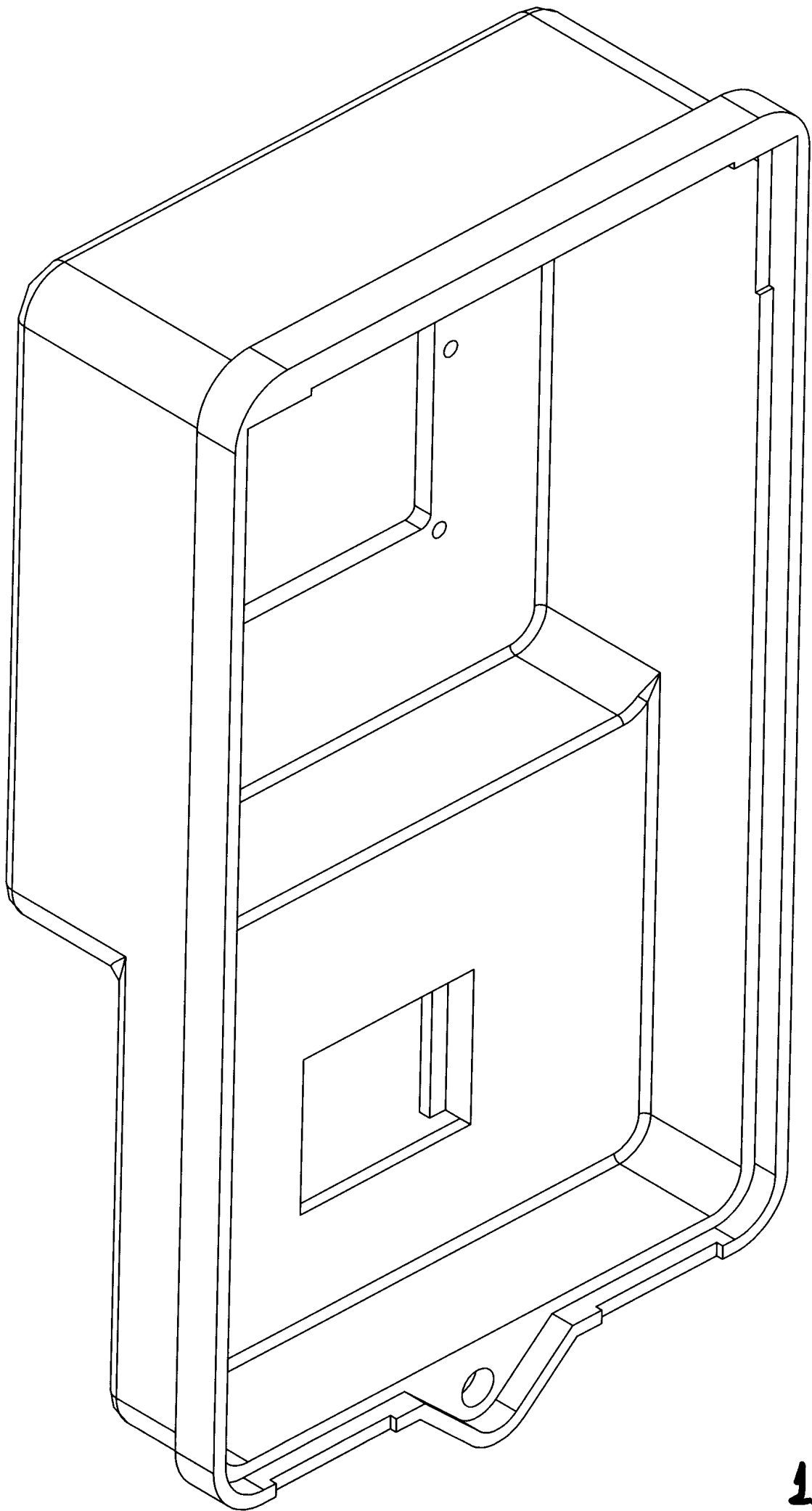

1 φ/21

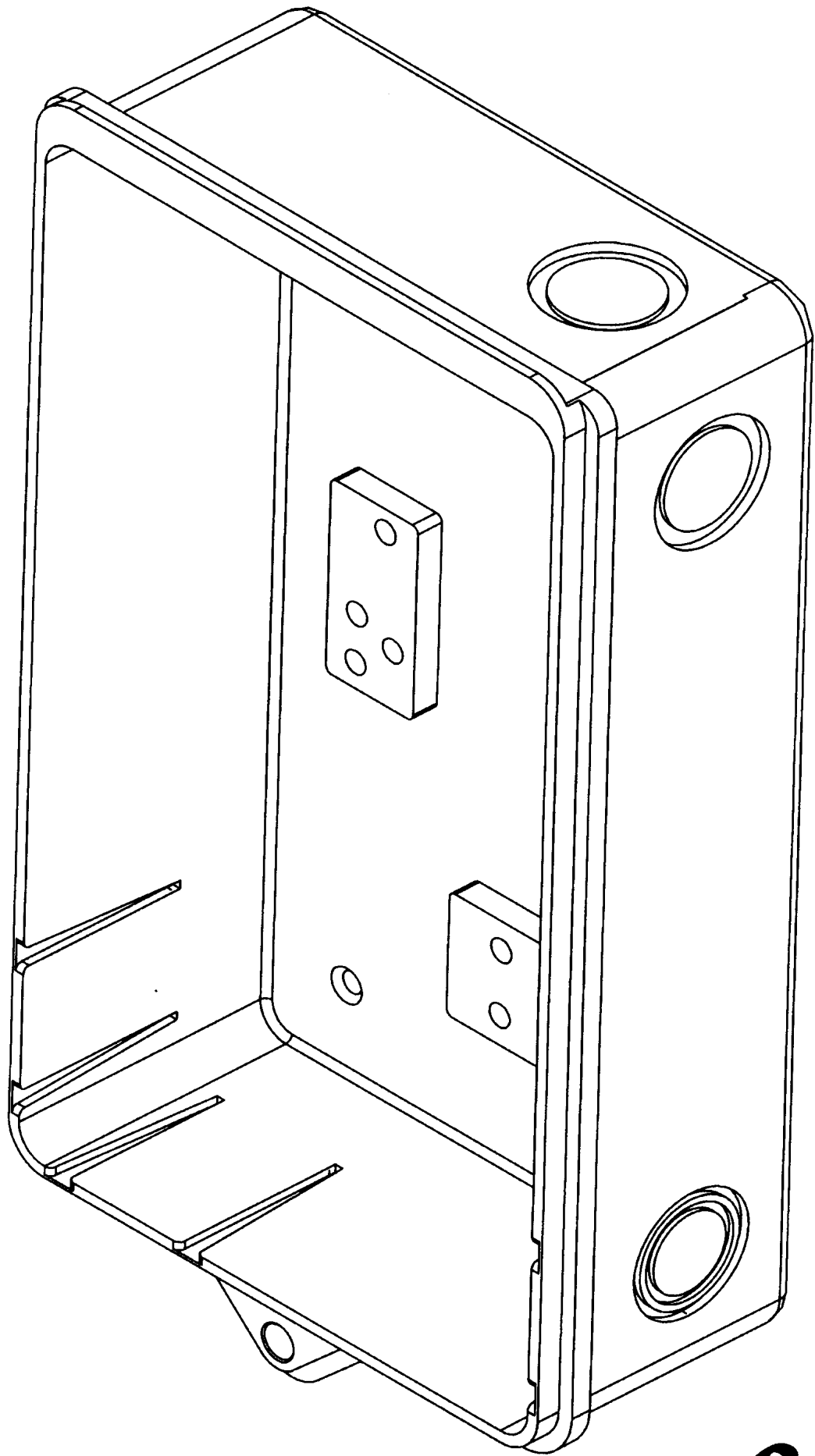

2/21

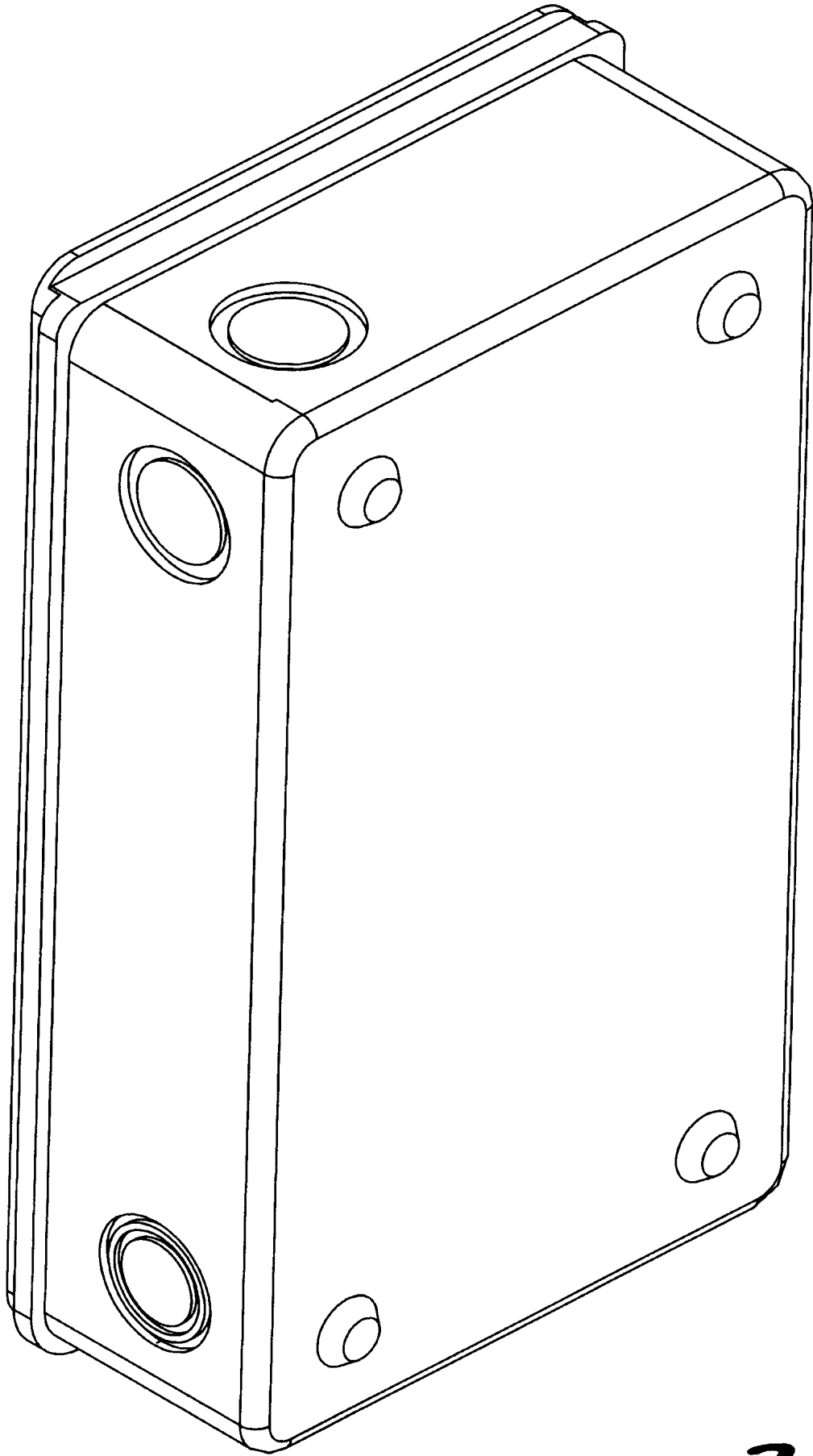

3/21

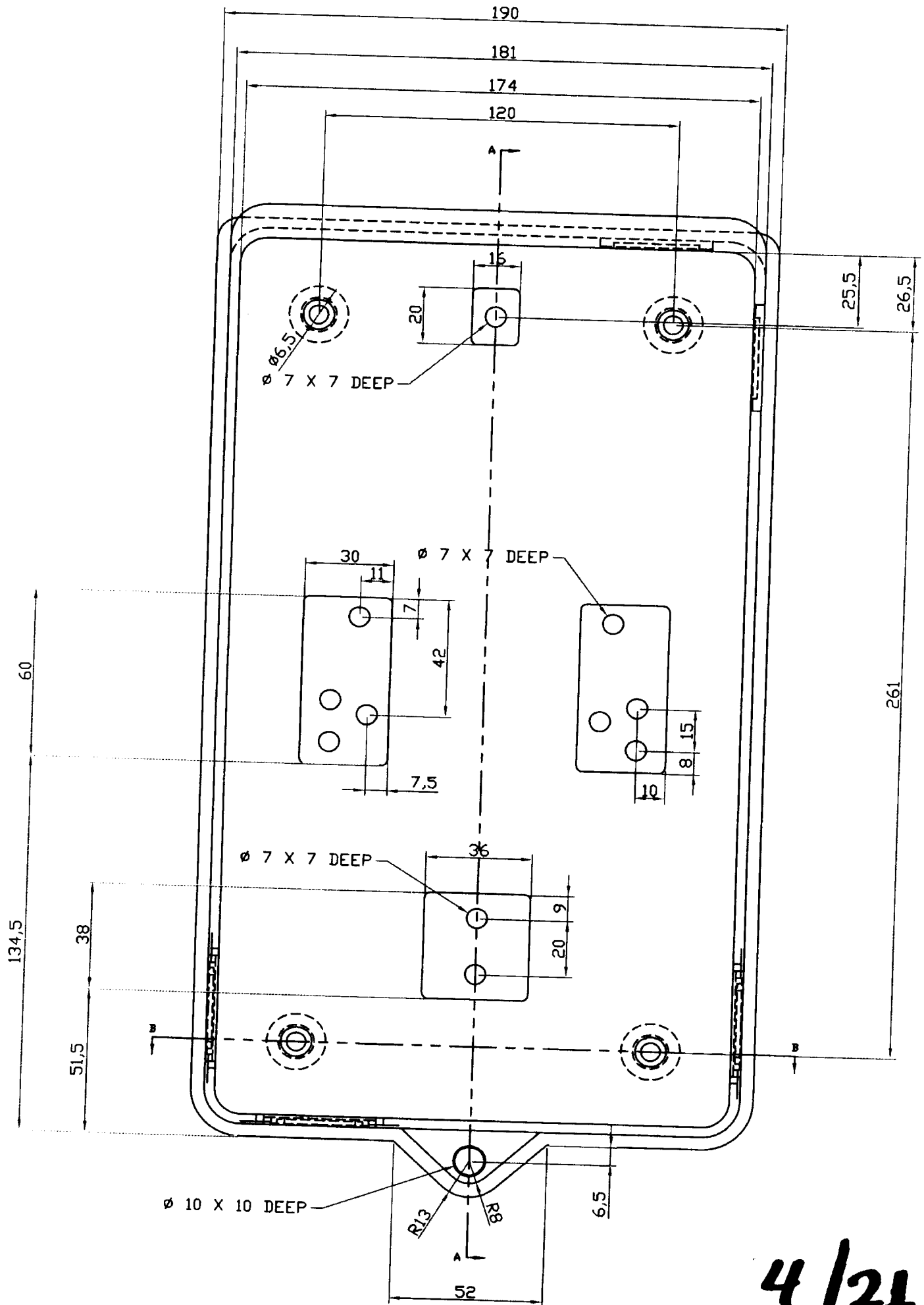

4/21

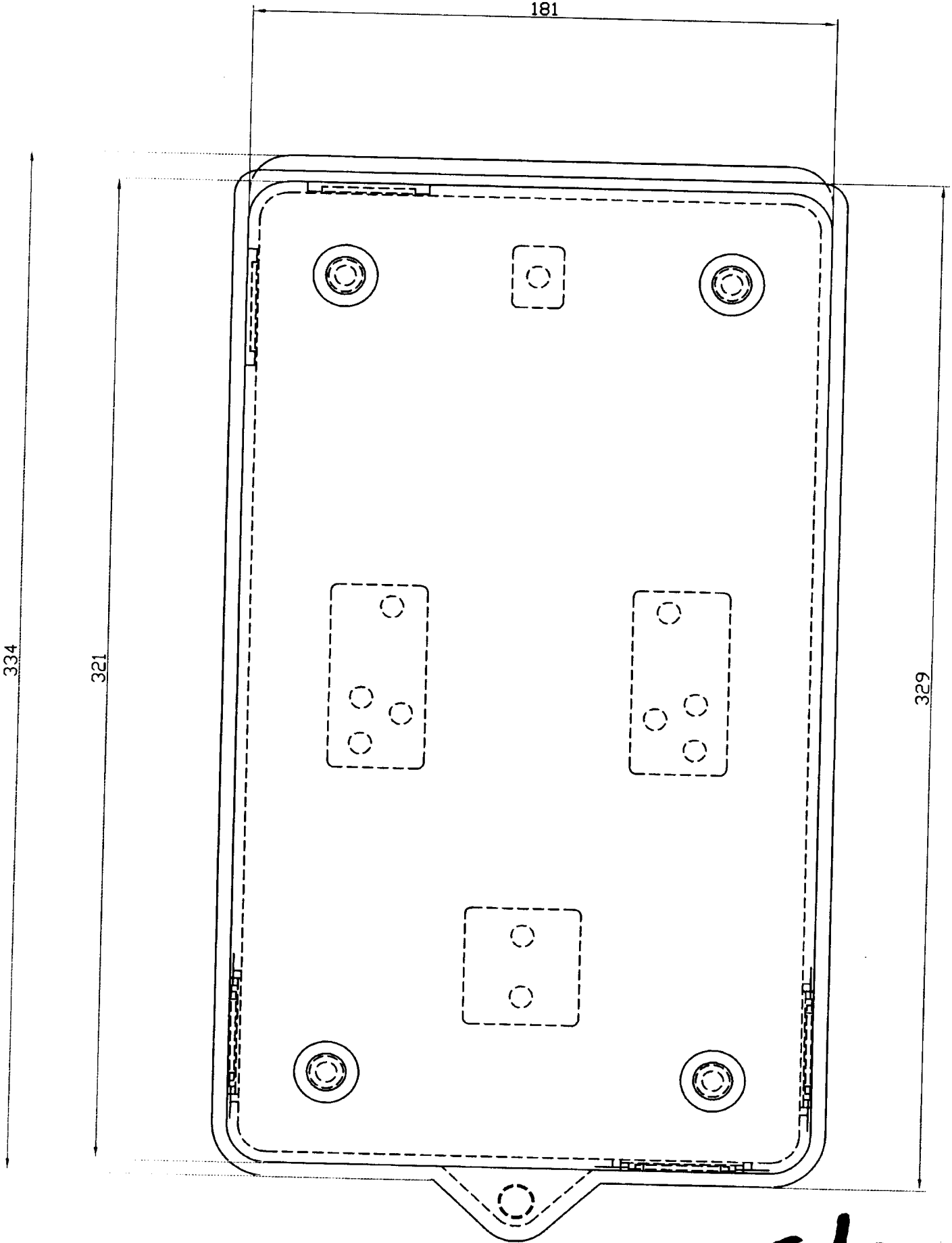

5/21

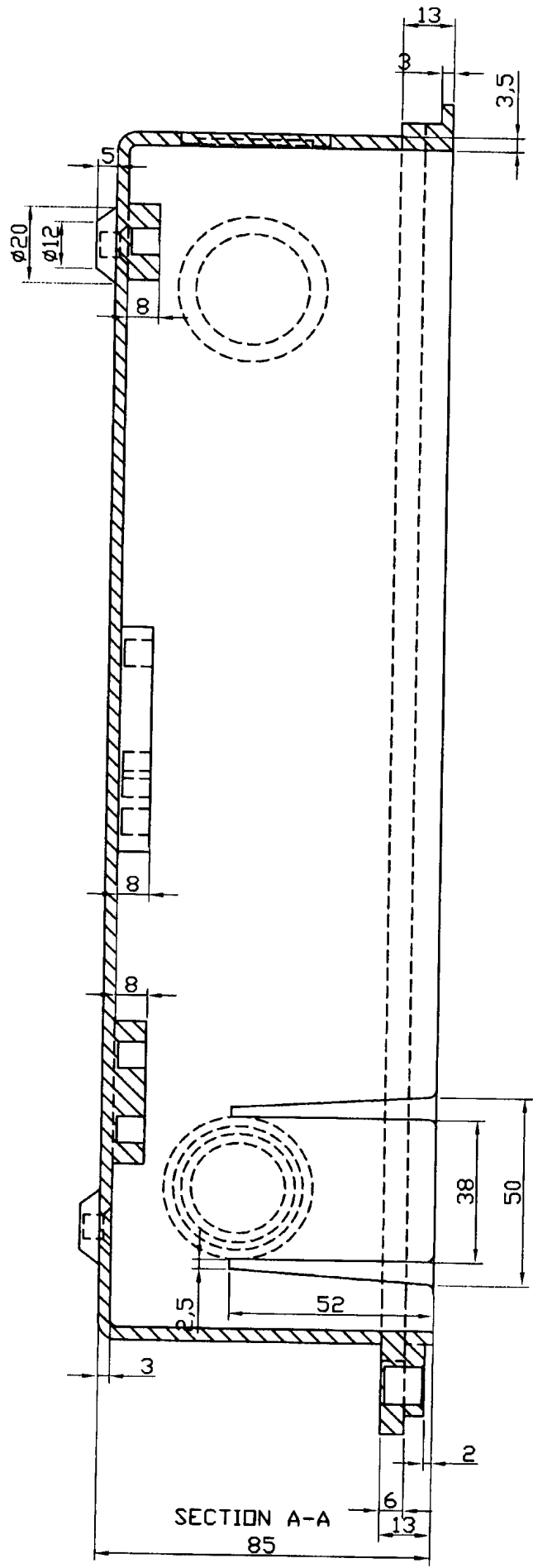

6/21

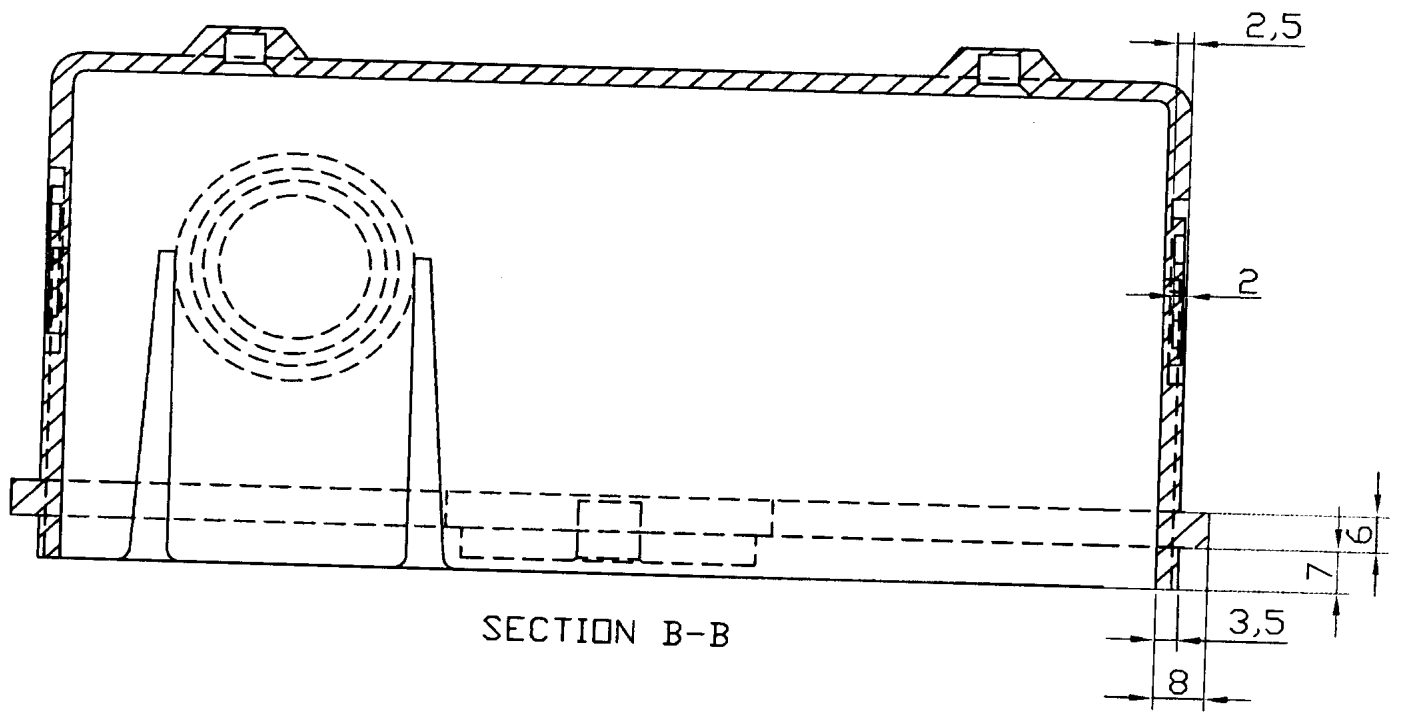

7/21

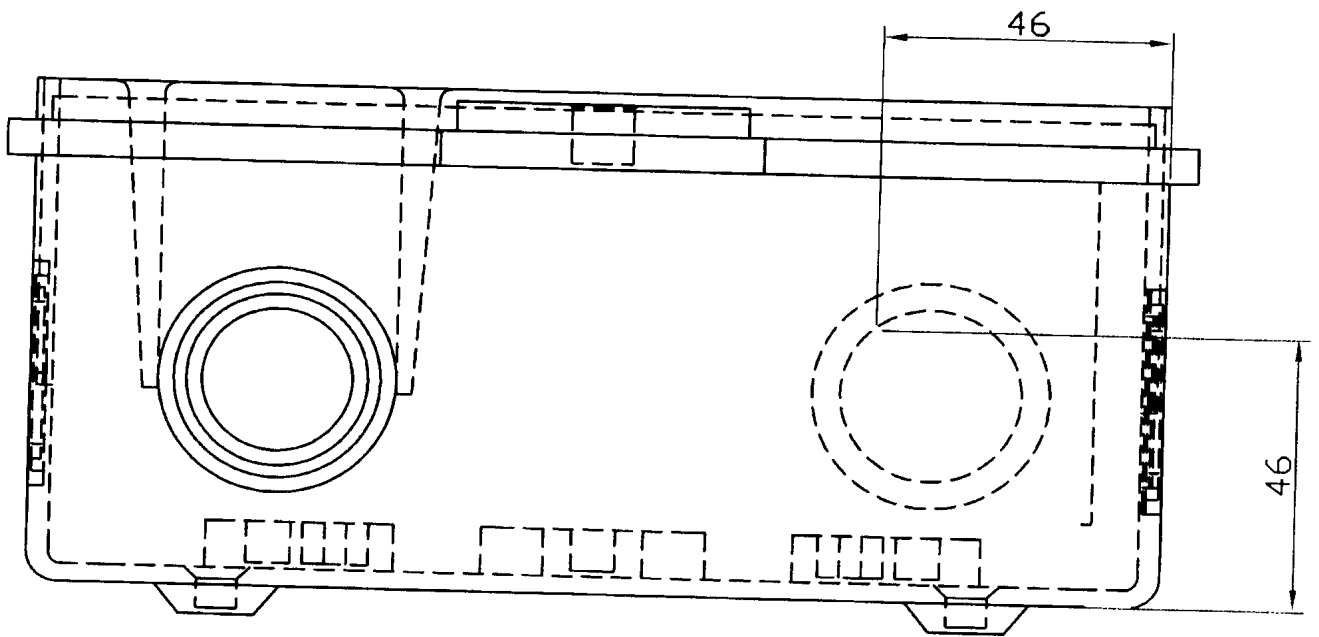

8/21

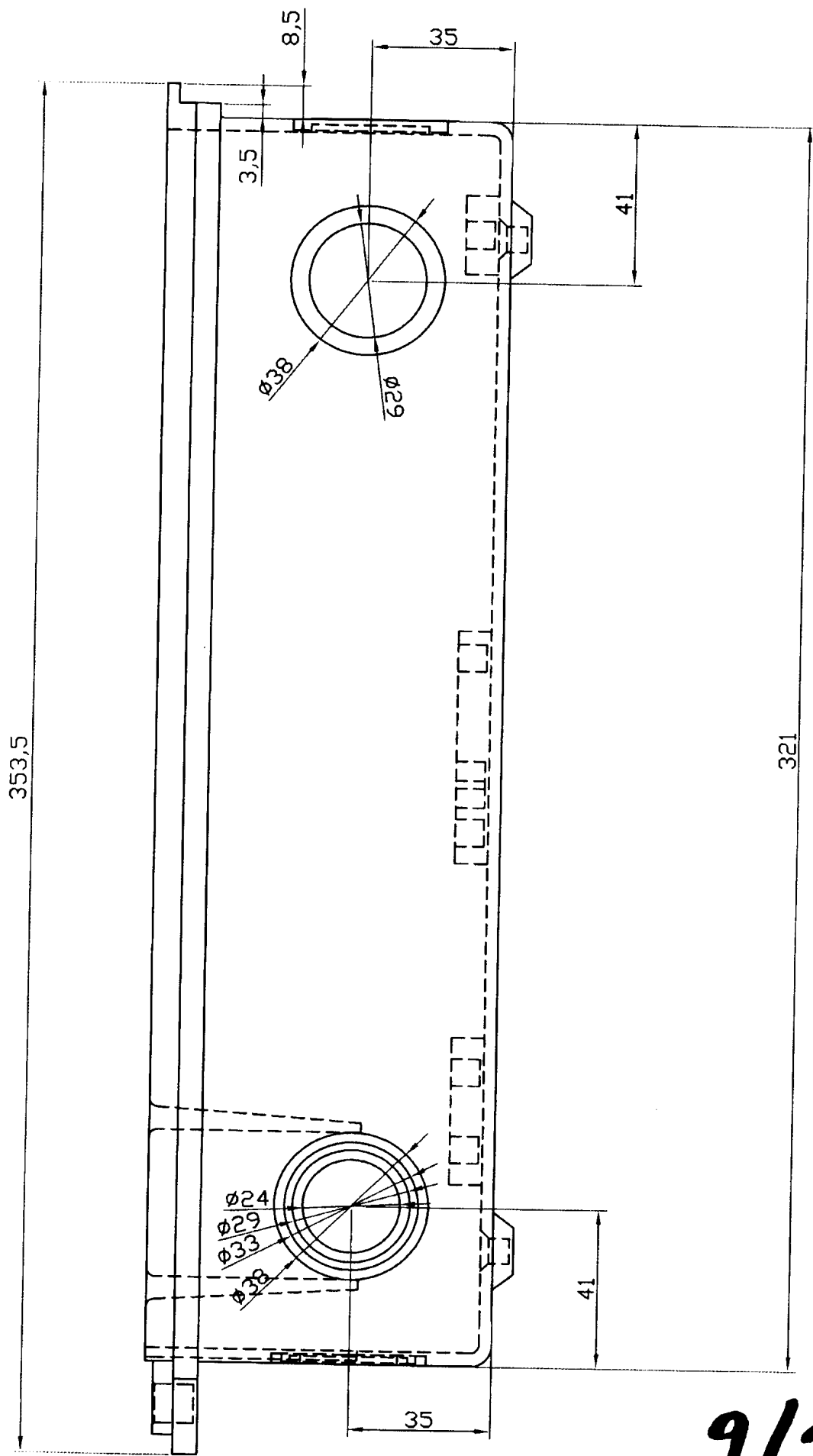

9/21

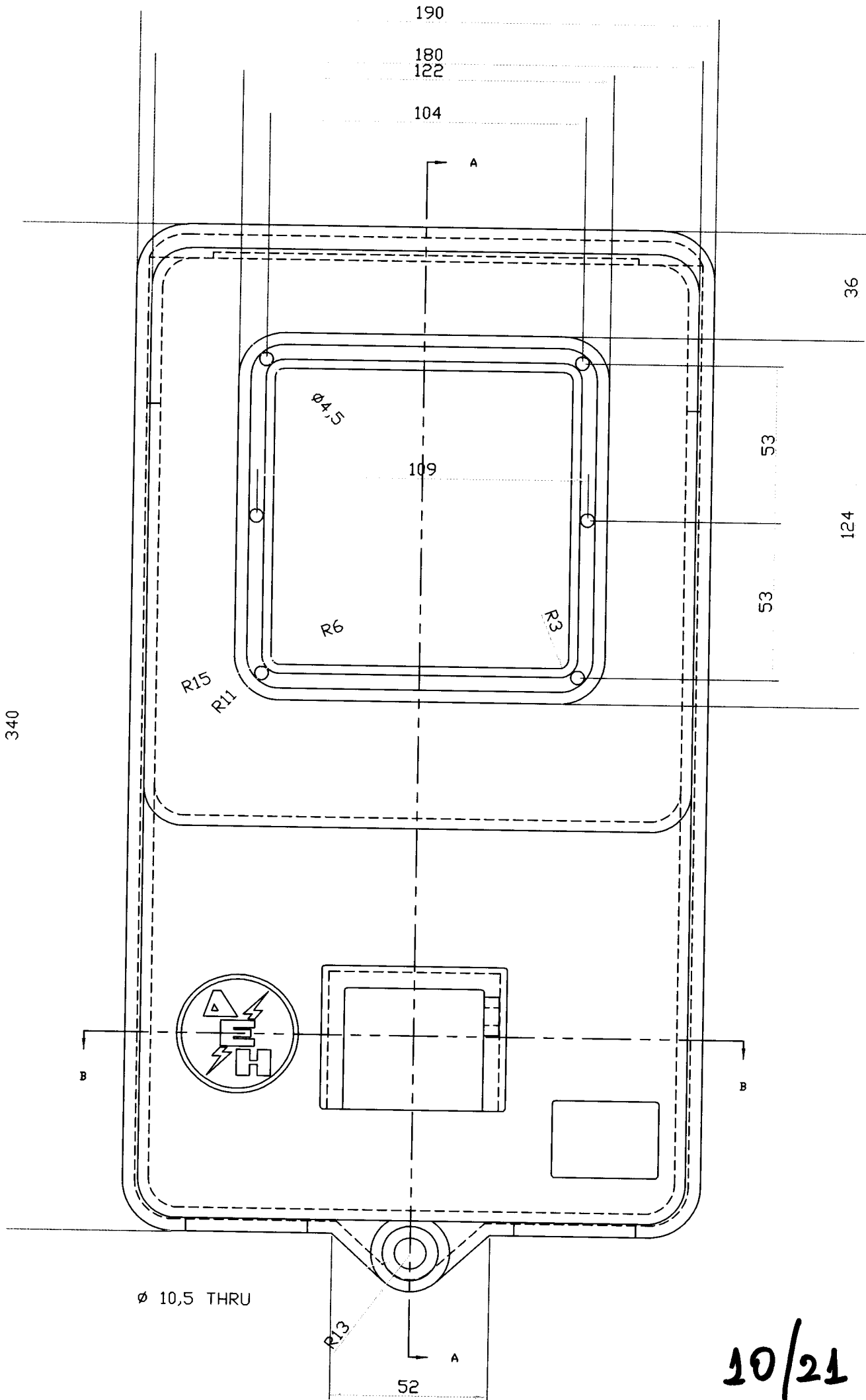

10/21

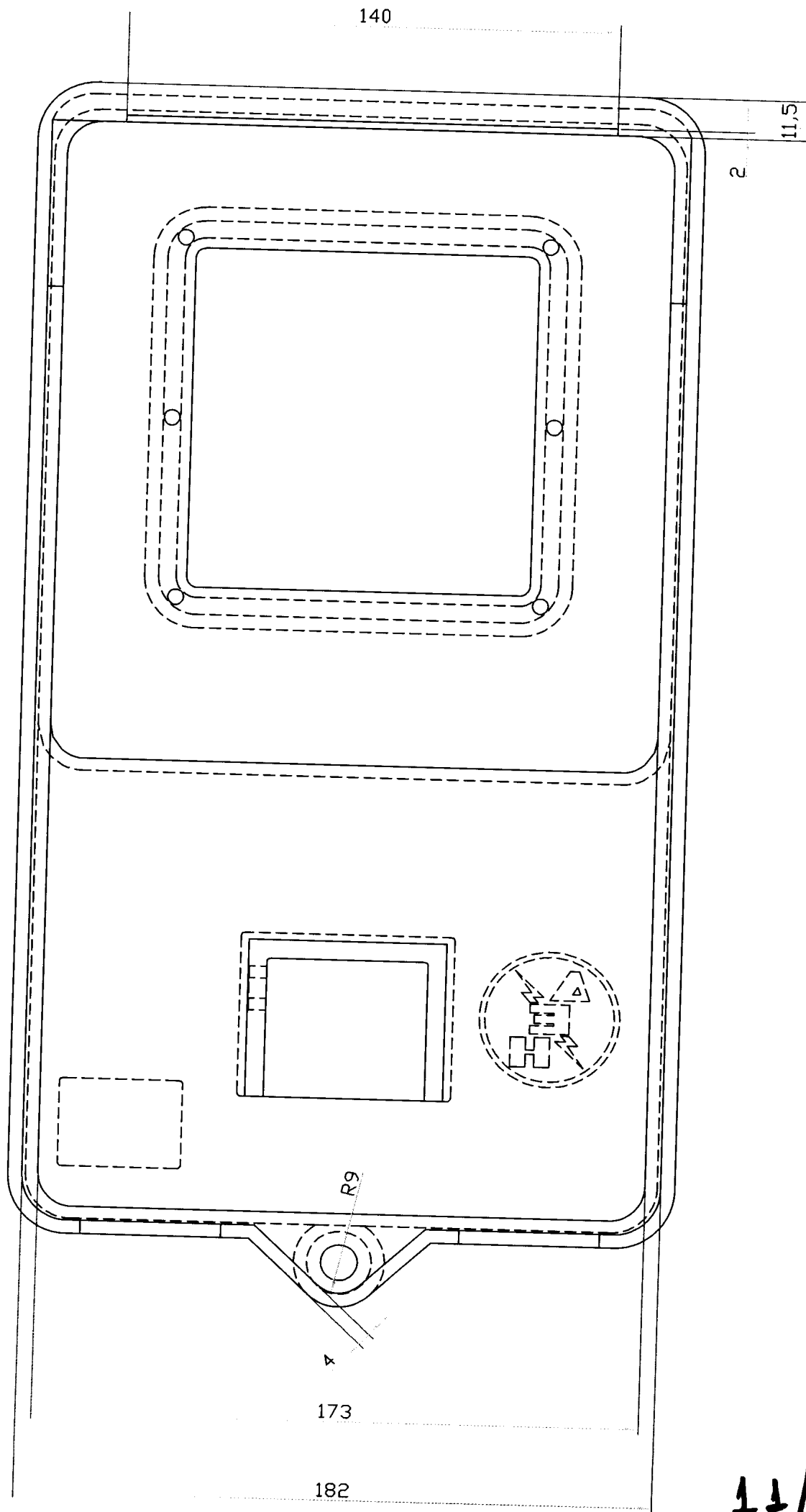

11/21

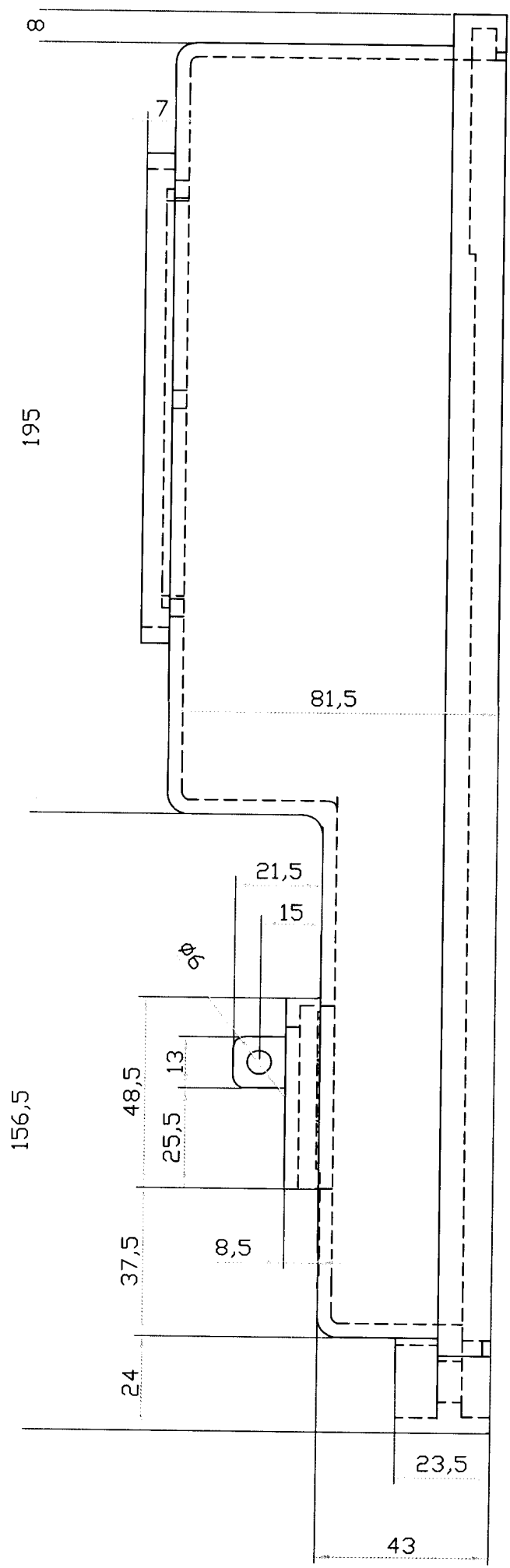

12/21

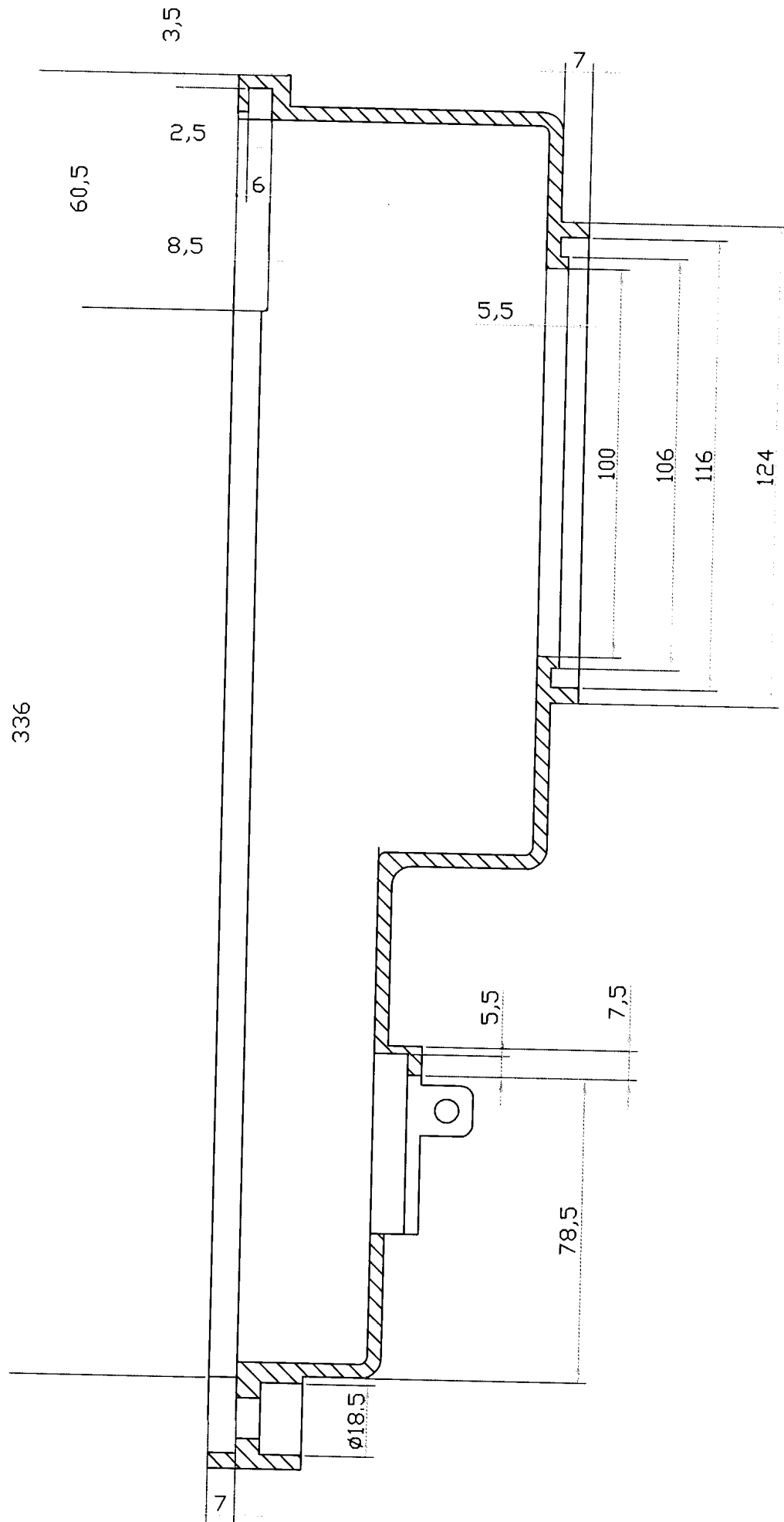

SECTION A-A

13/21

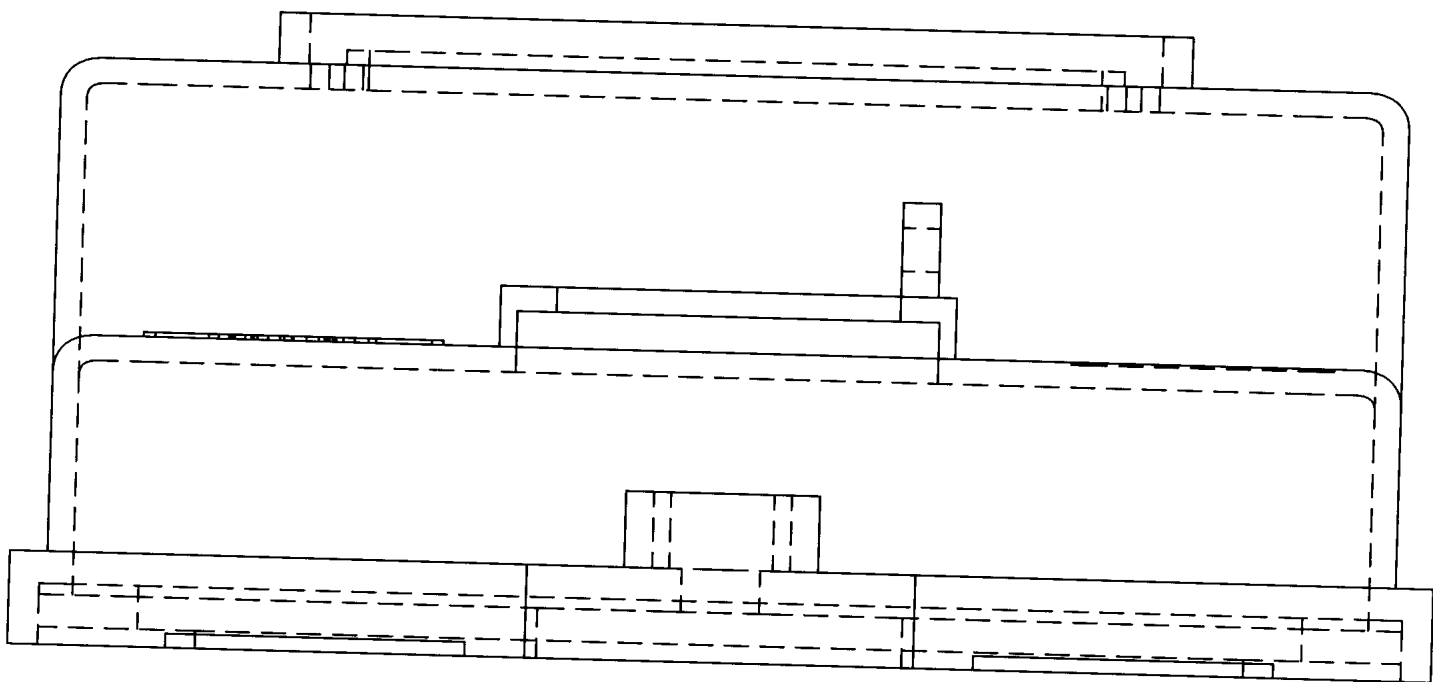

14/21

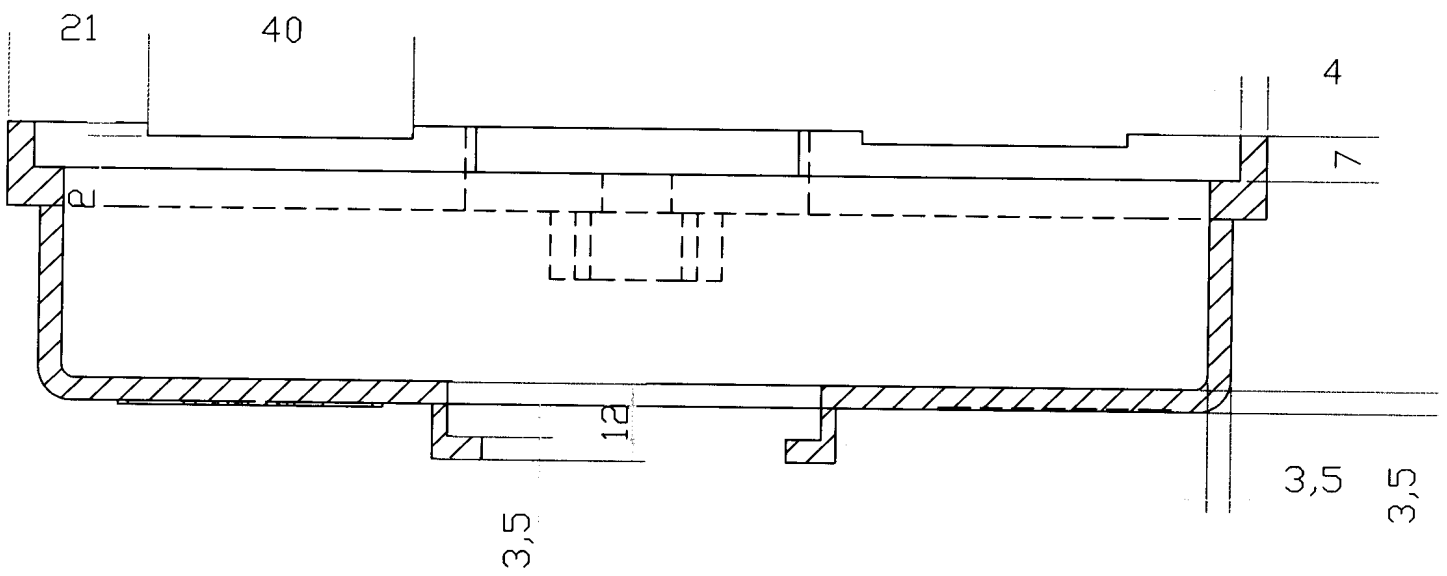

SECTION B-B

15/21

113

104

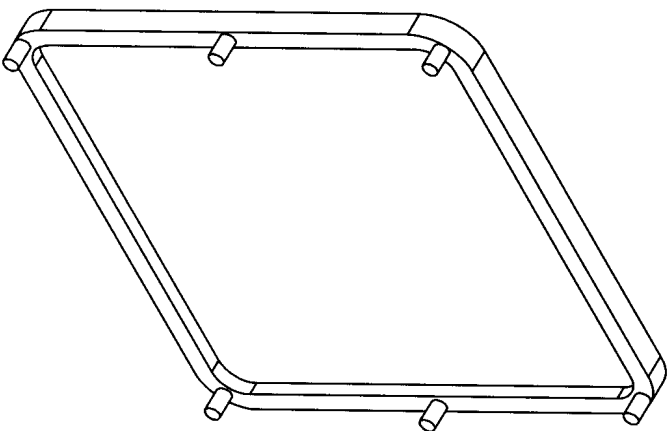
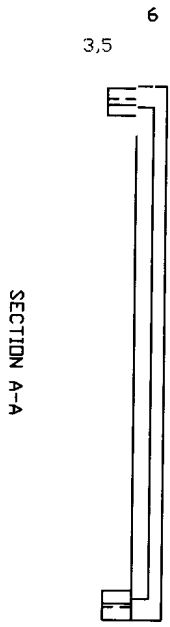
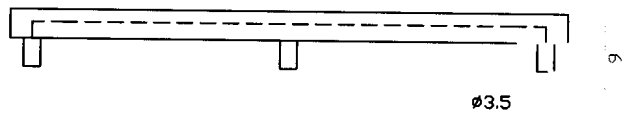
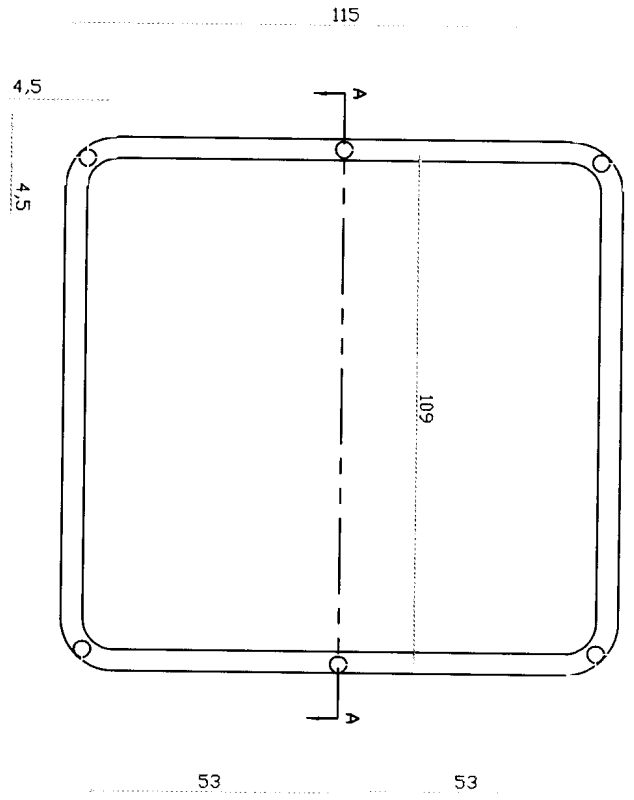

16/21

56

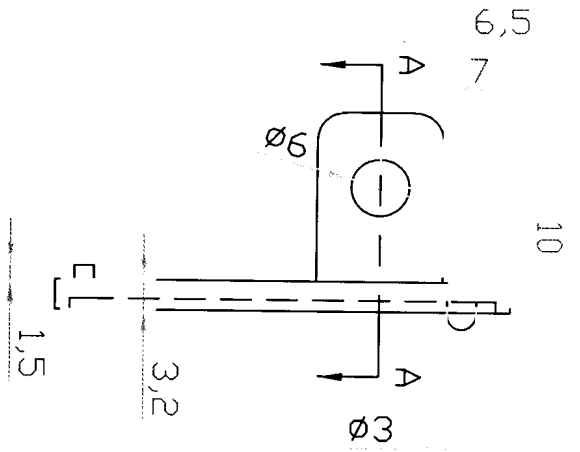
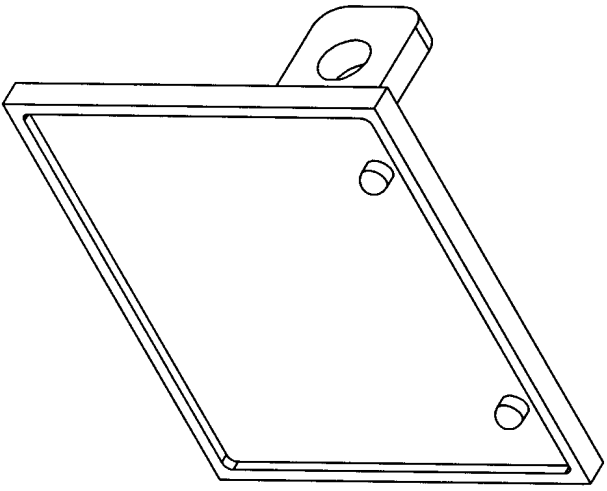
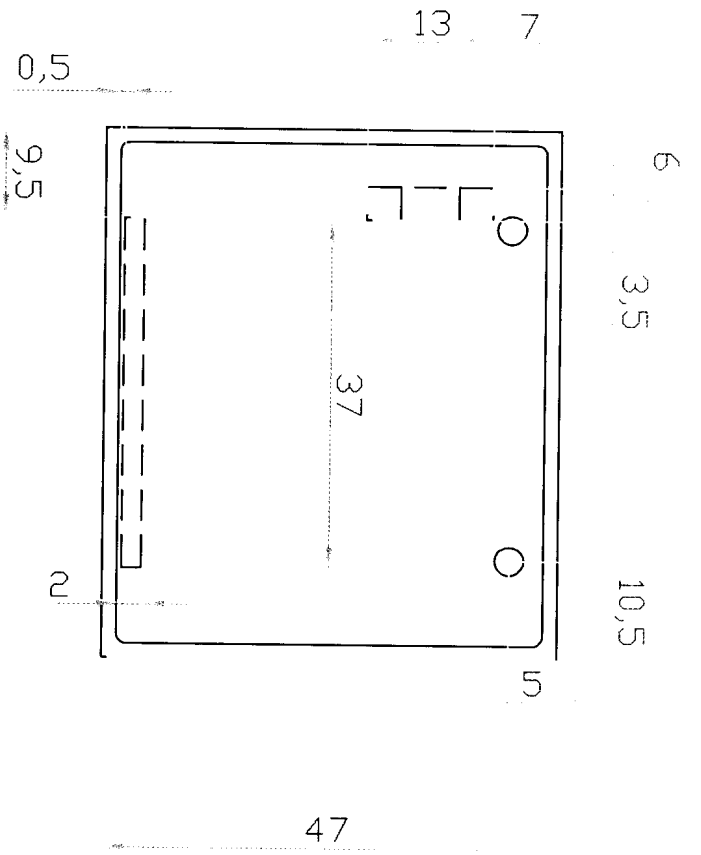

SECTION A-A

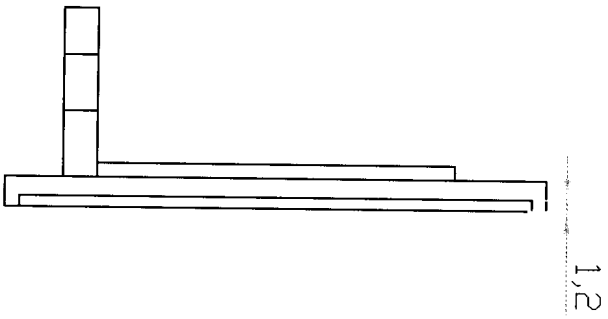

17/21

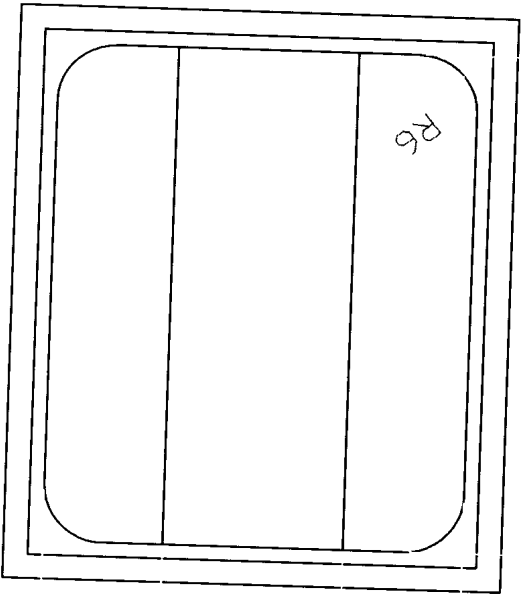

53

61

18,5

43

51

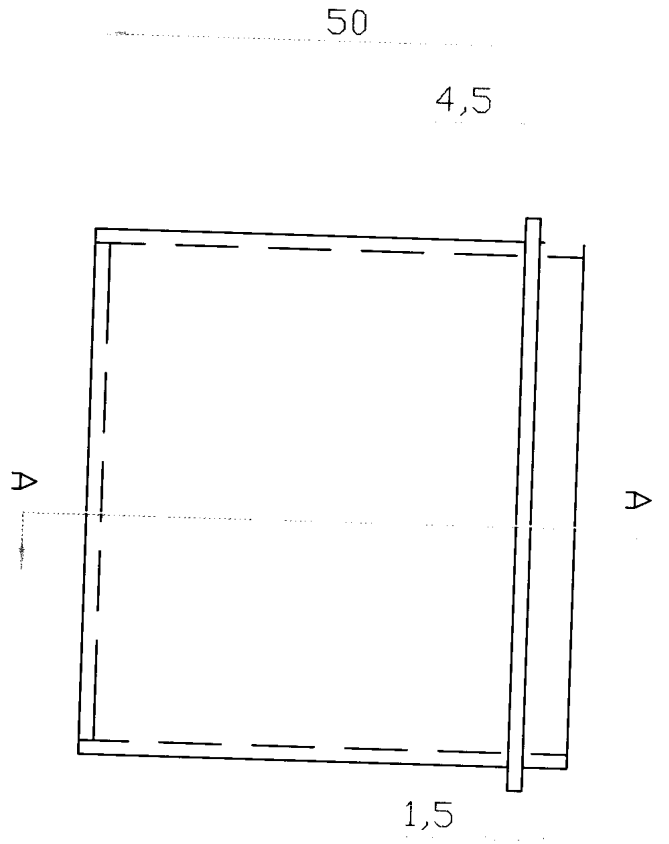

1,5

56

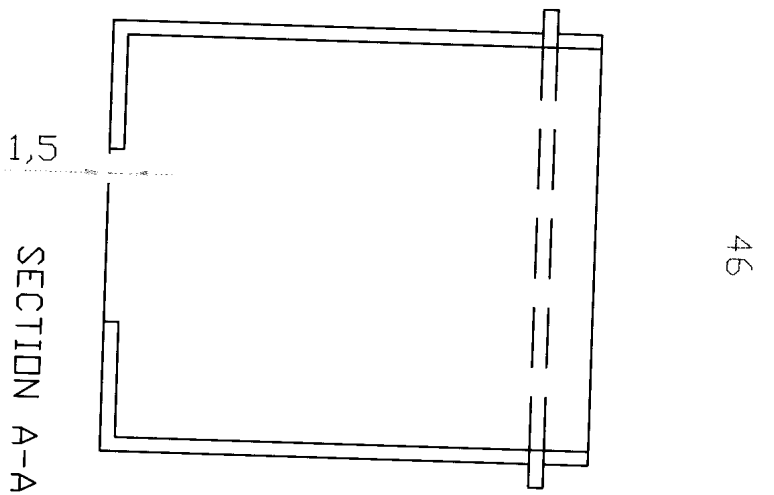

46

18/21

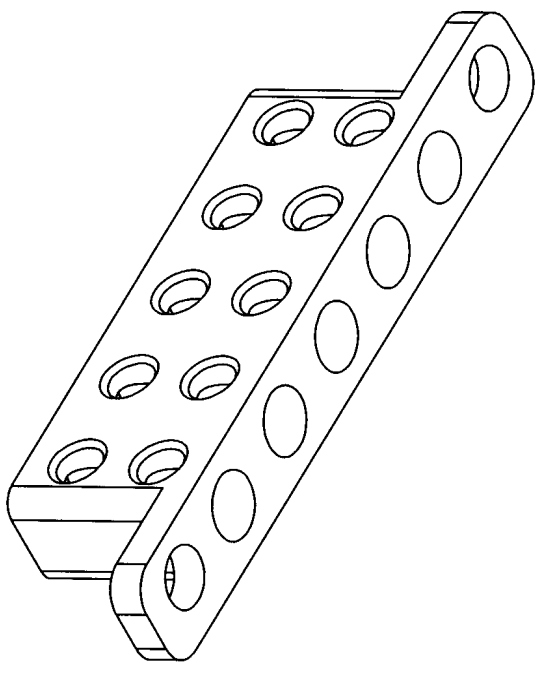
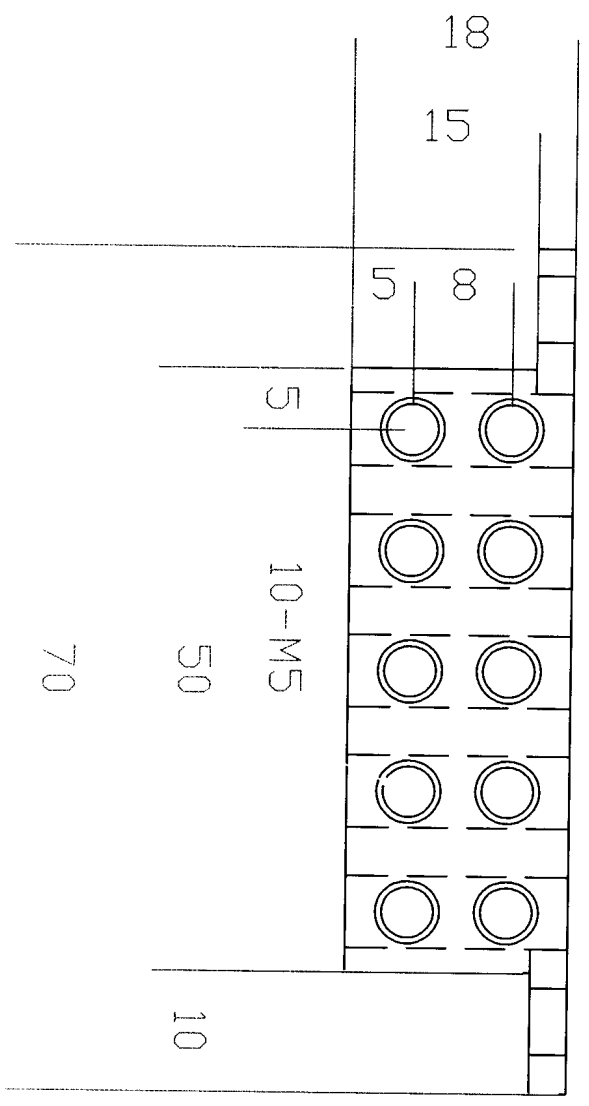
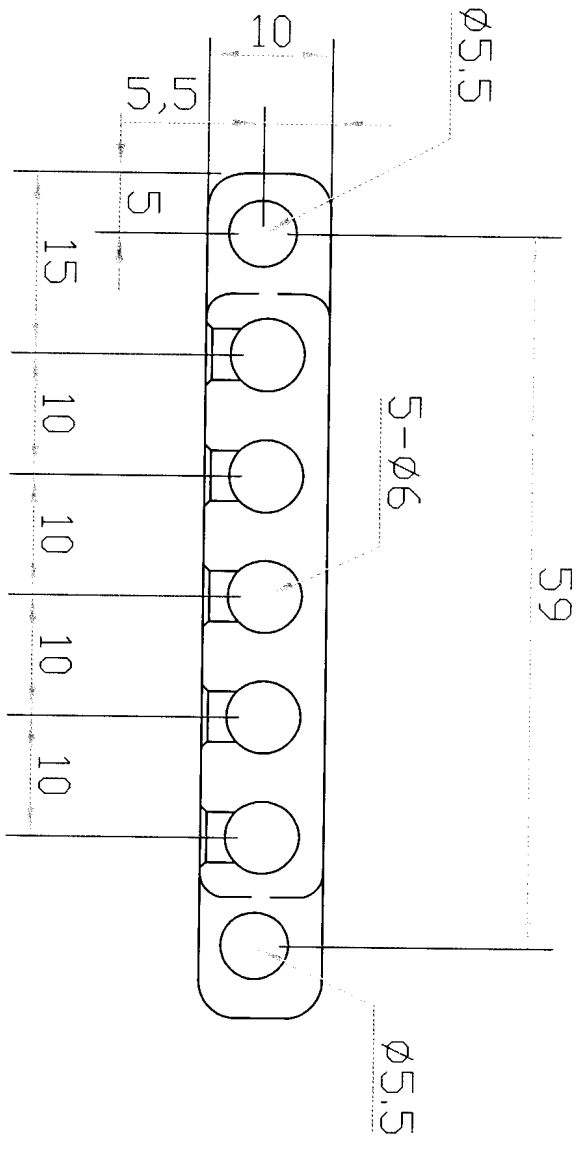

L9/21

1,5

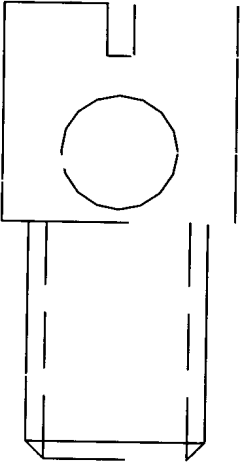

∅6,5

M10

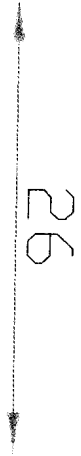

26

12,5

8,5

3

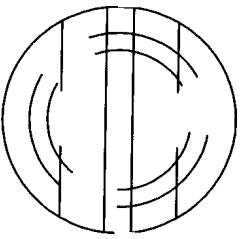

13

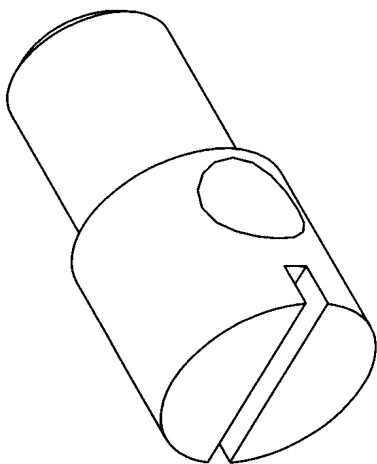

20/21

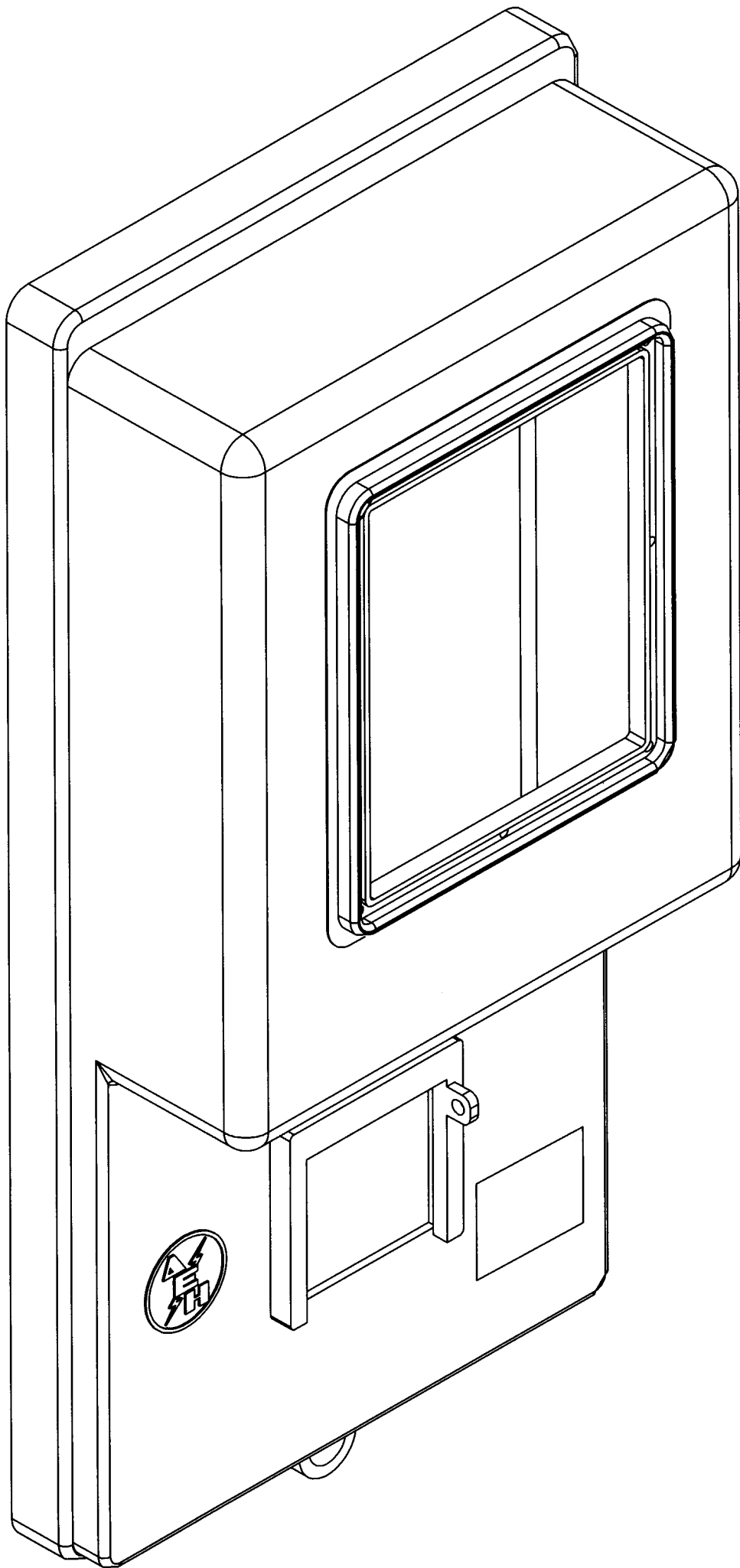

3φ

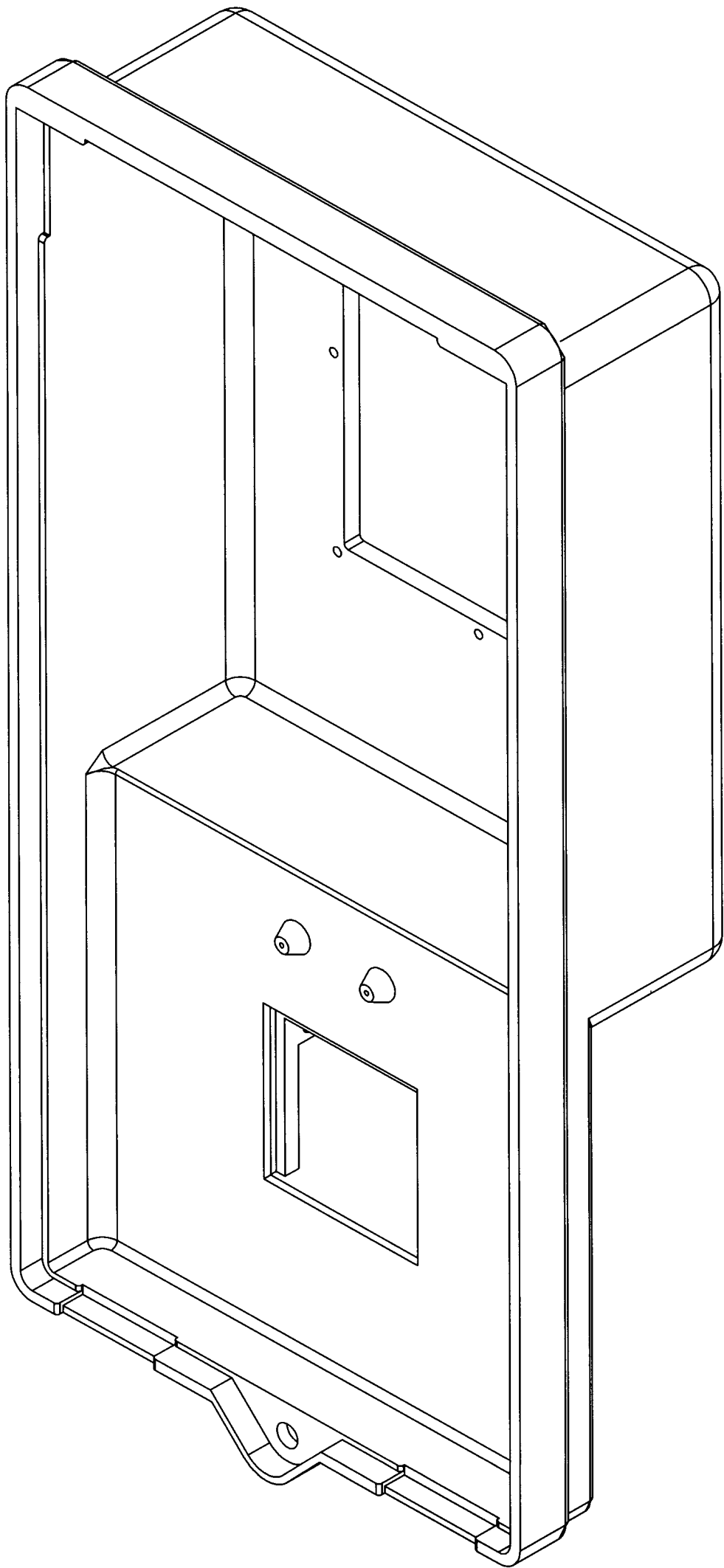

3/φ.

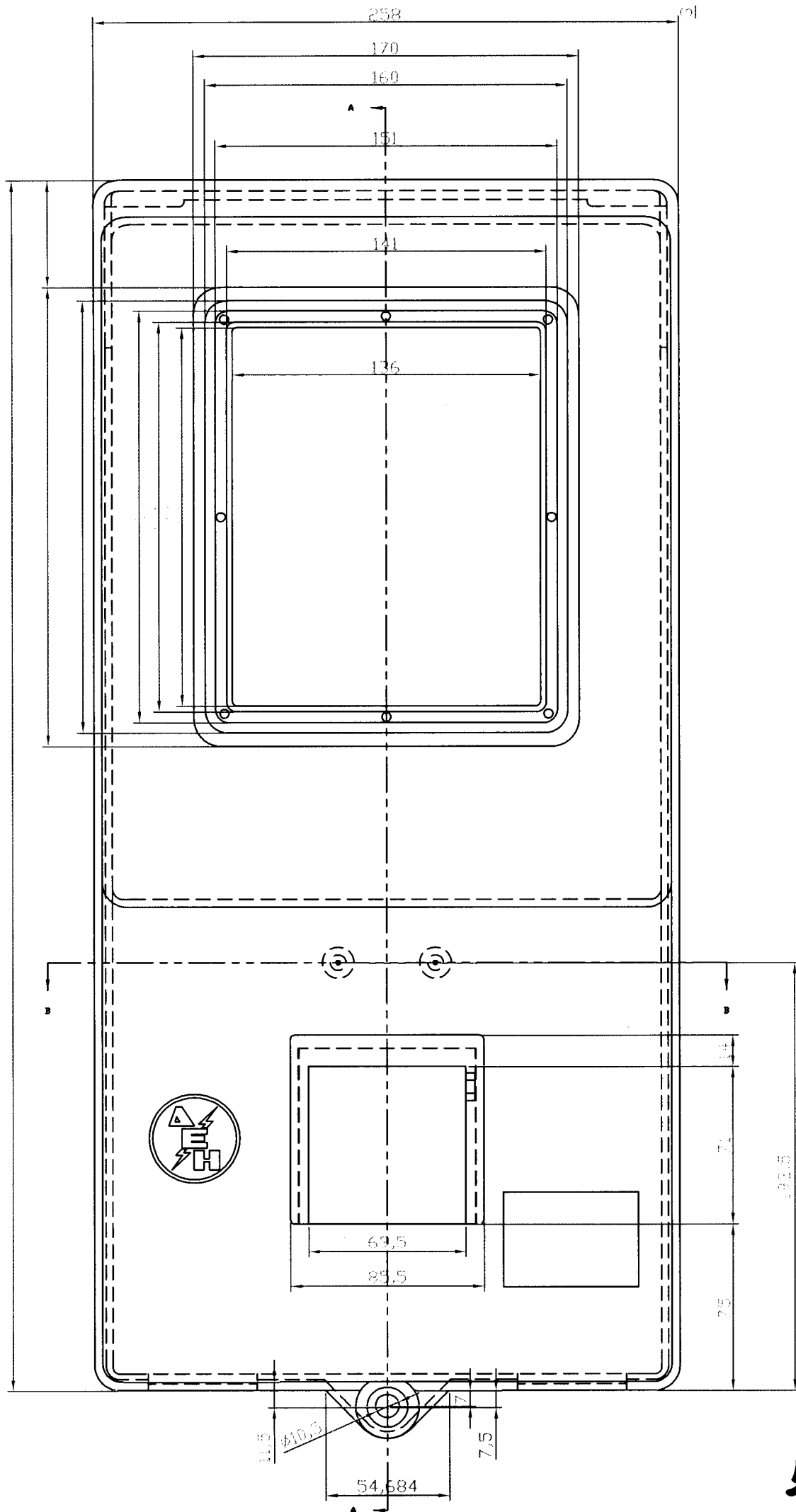

2/24

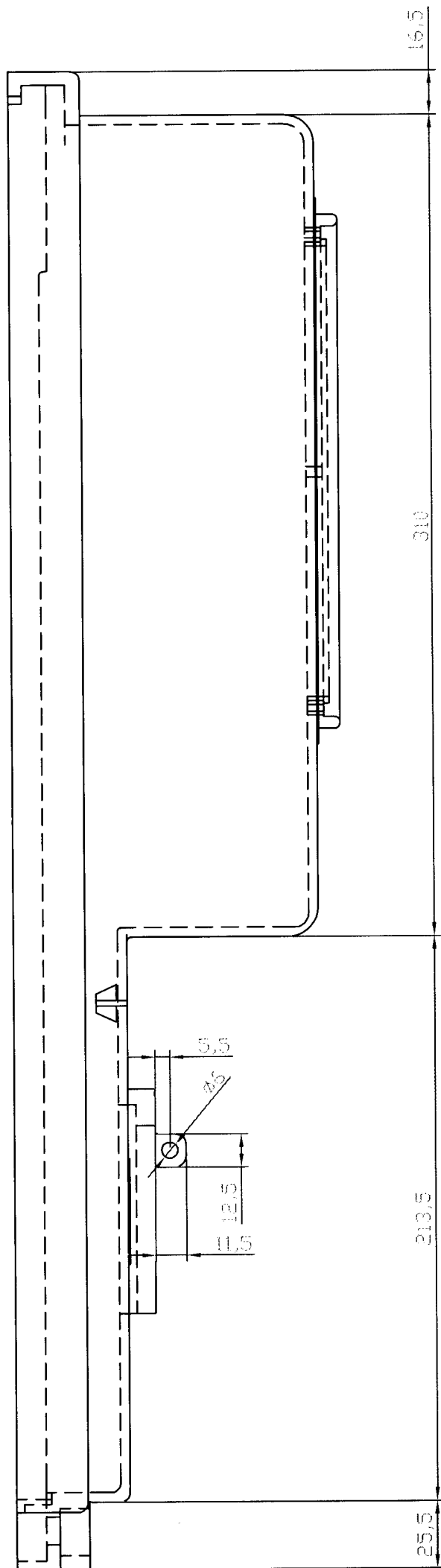

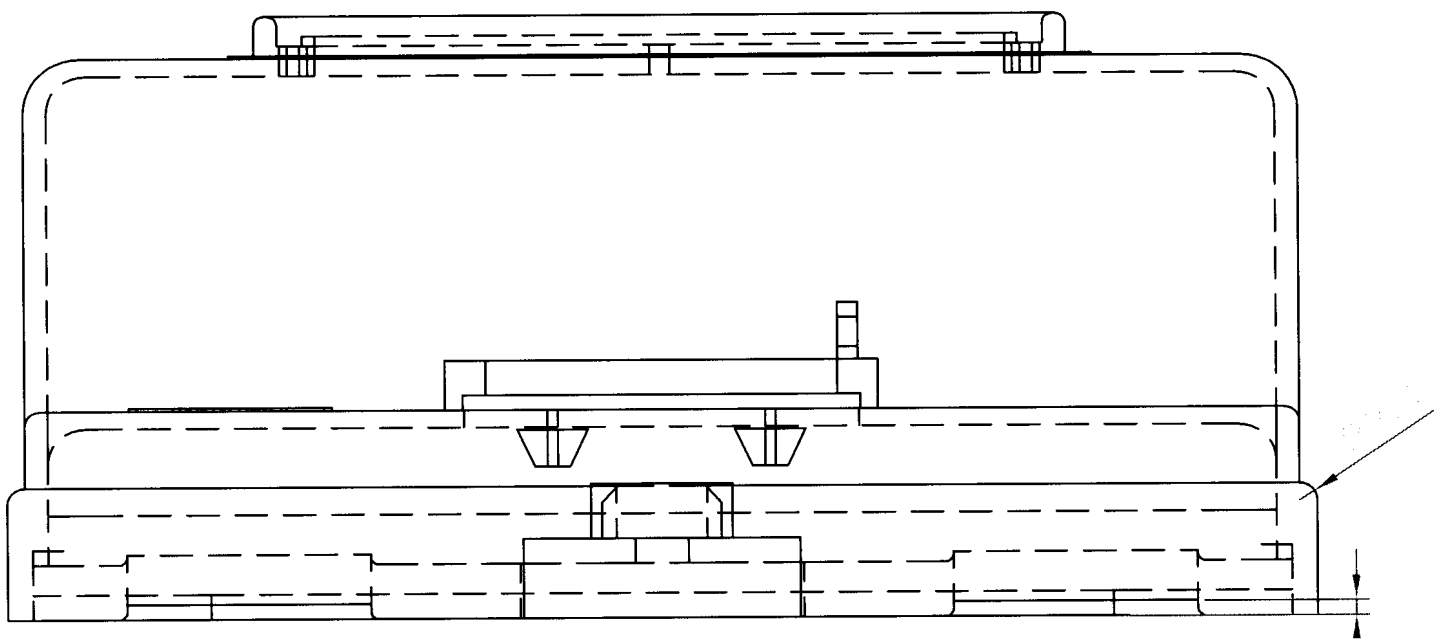

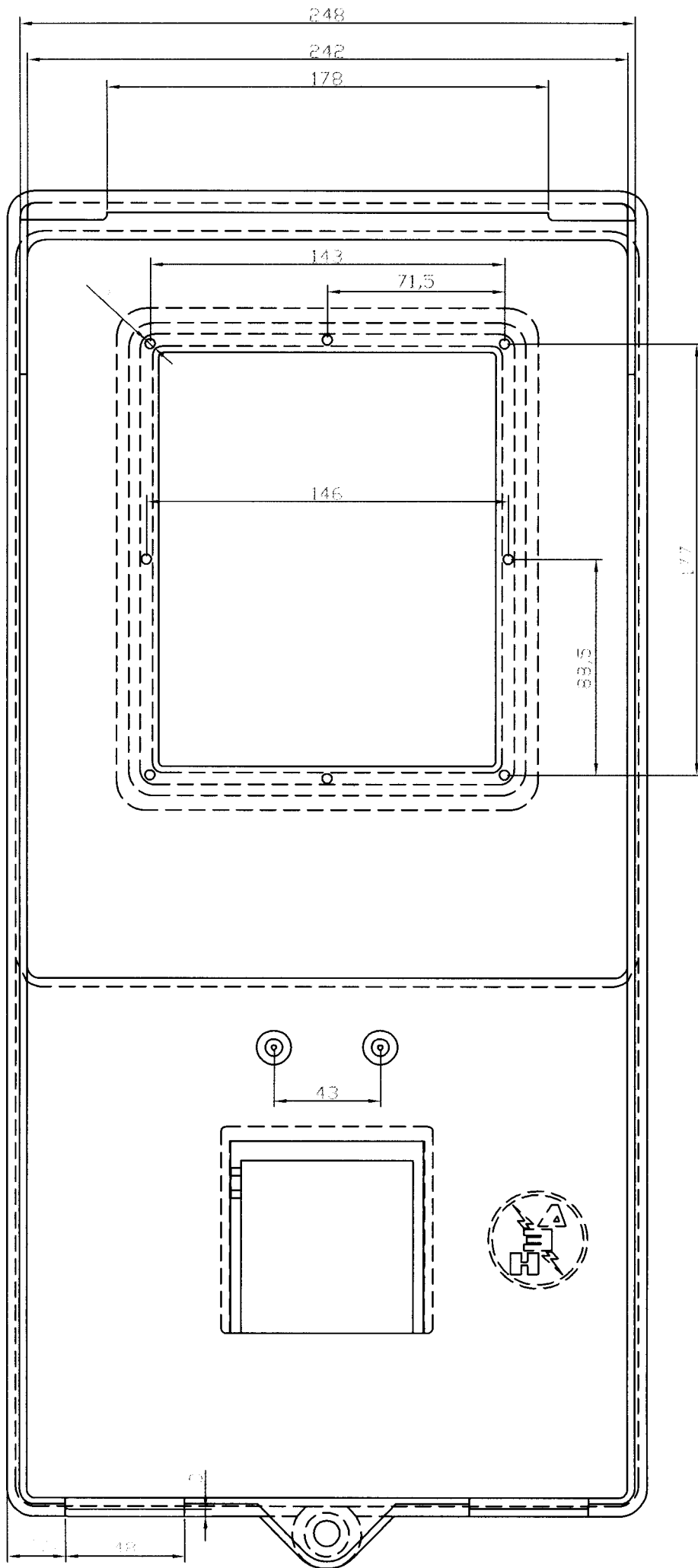

4/14

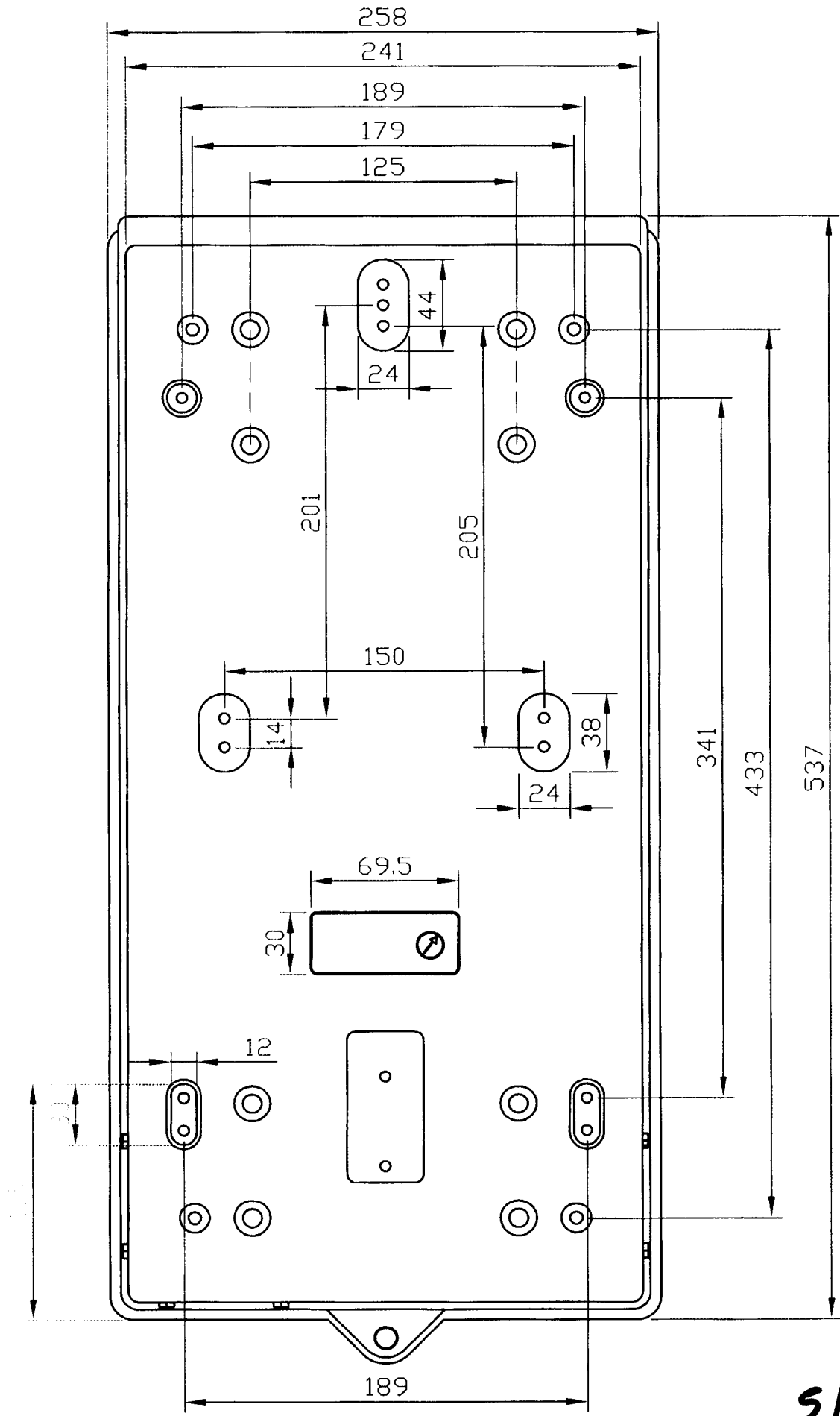

5/24

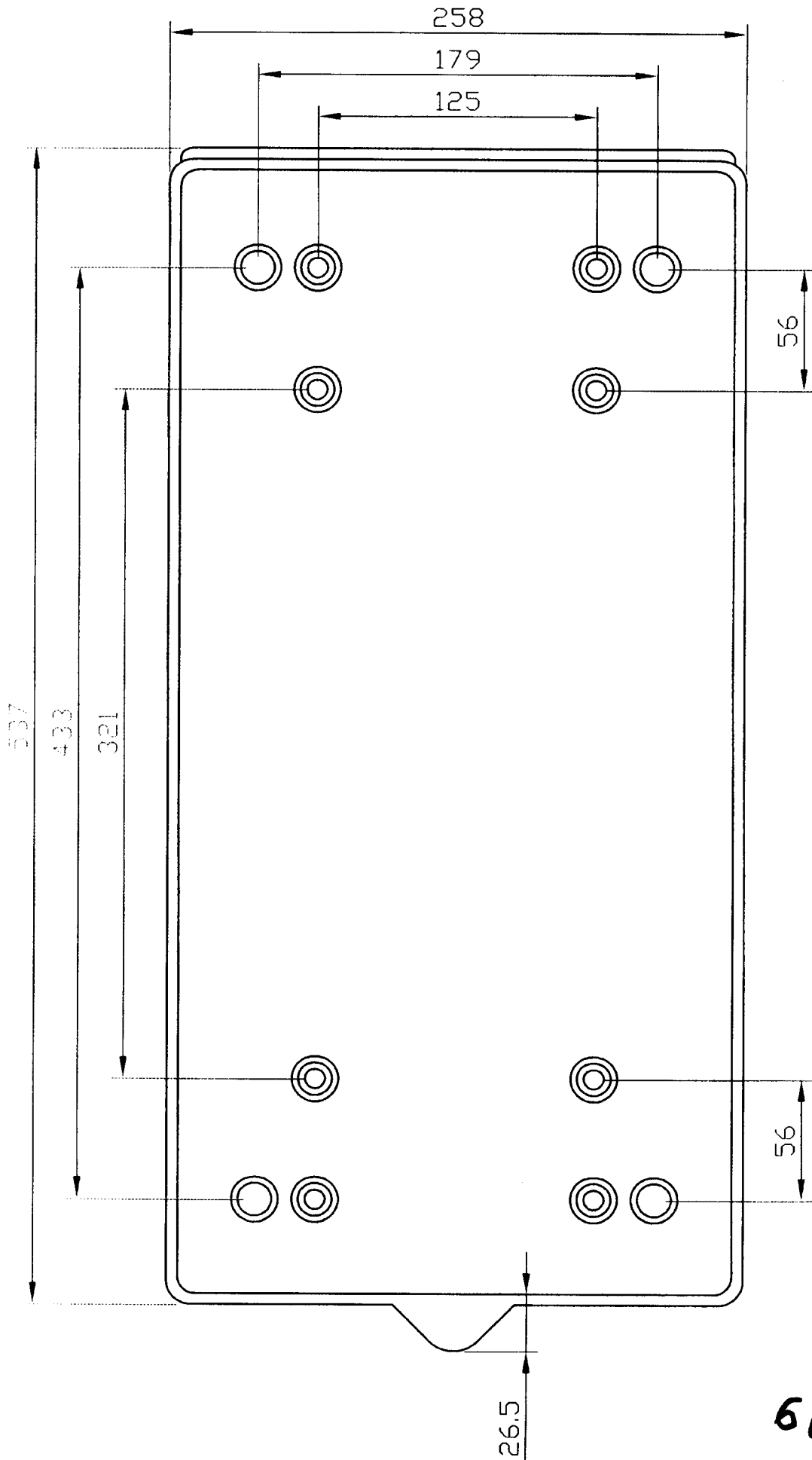

6/14

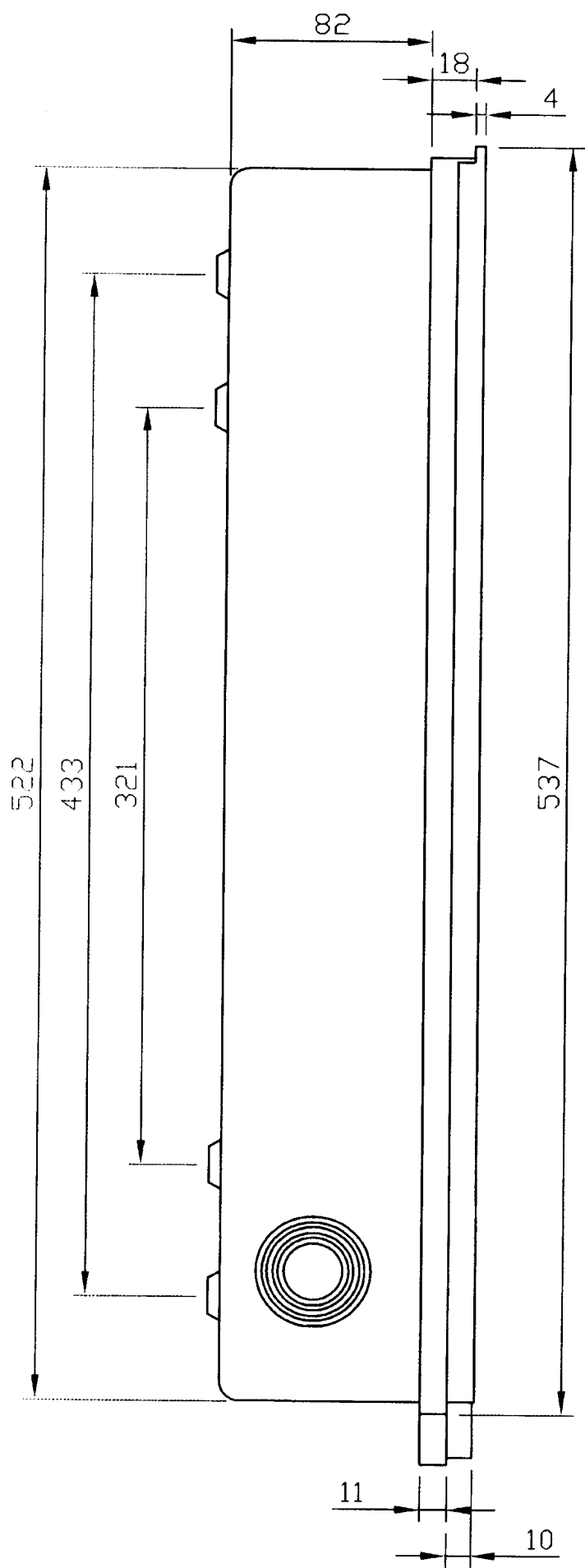

7/14

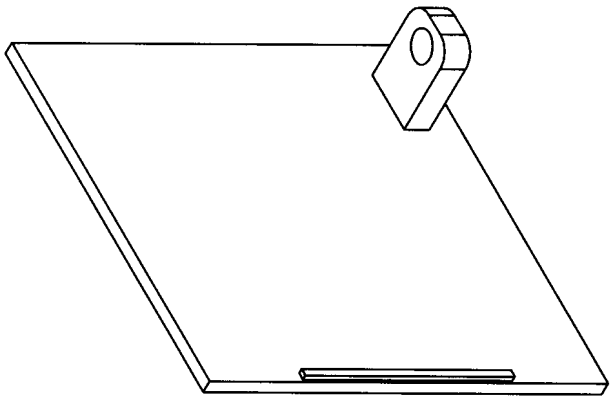
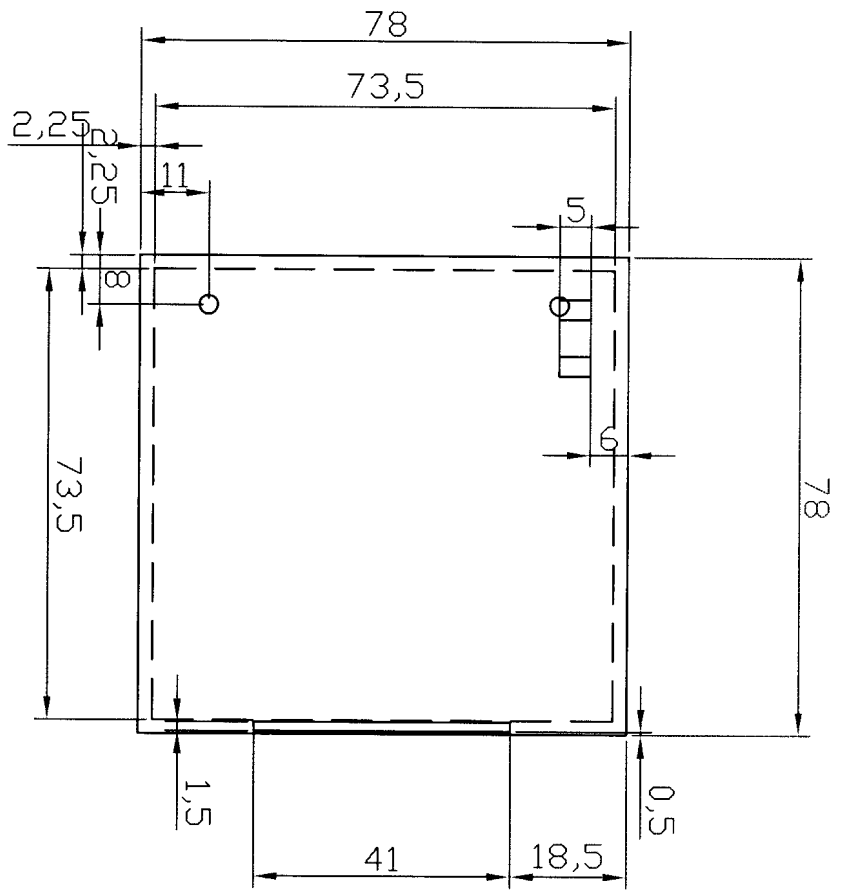
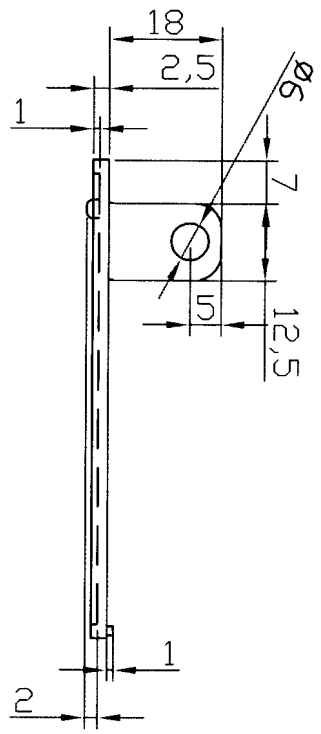

8/14

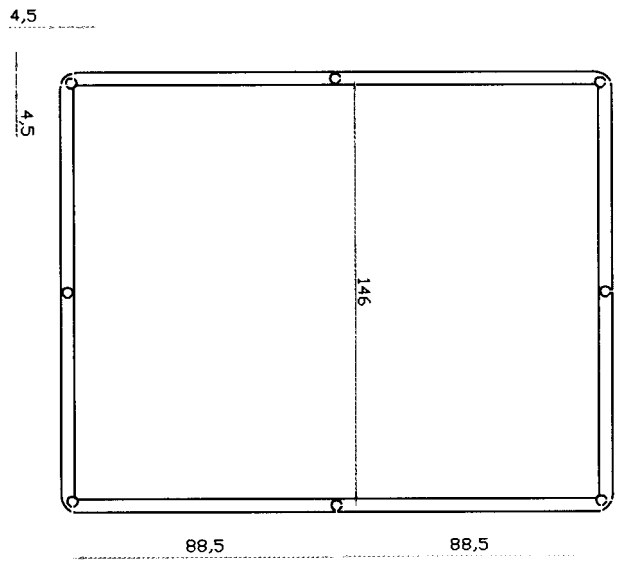
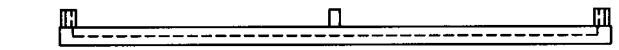
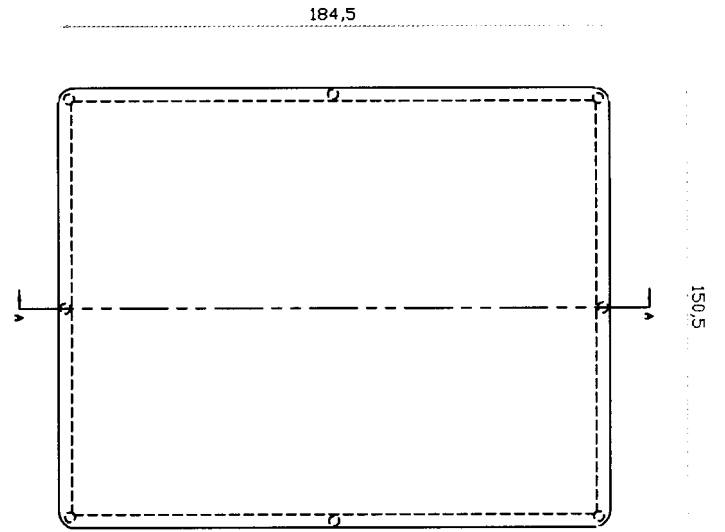
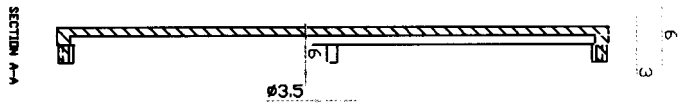
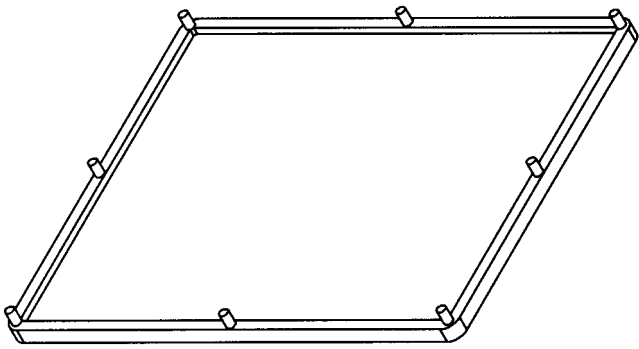

150,5
71,5

9/14

82,5

55

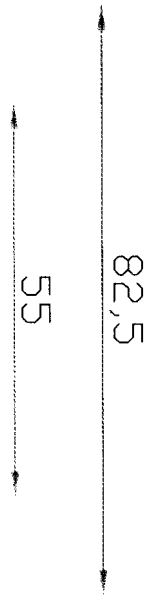
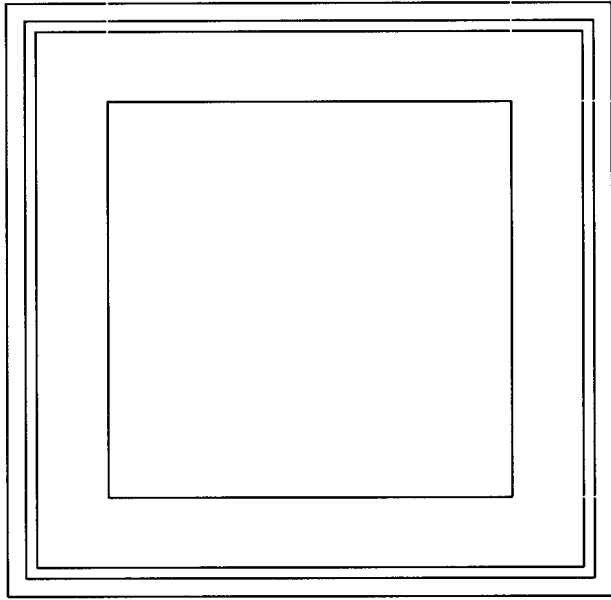

1,5

5

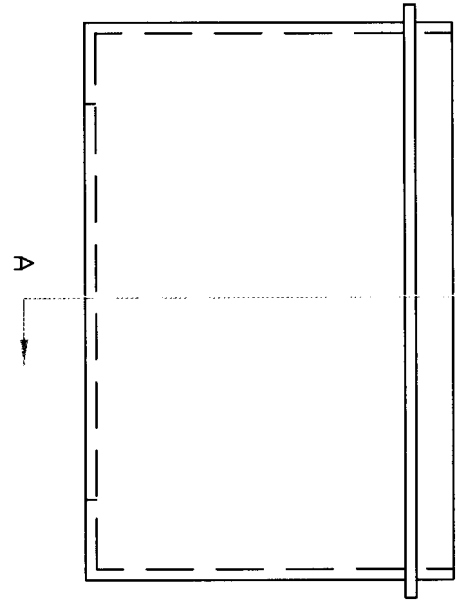

77,5

50

1,5

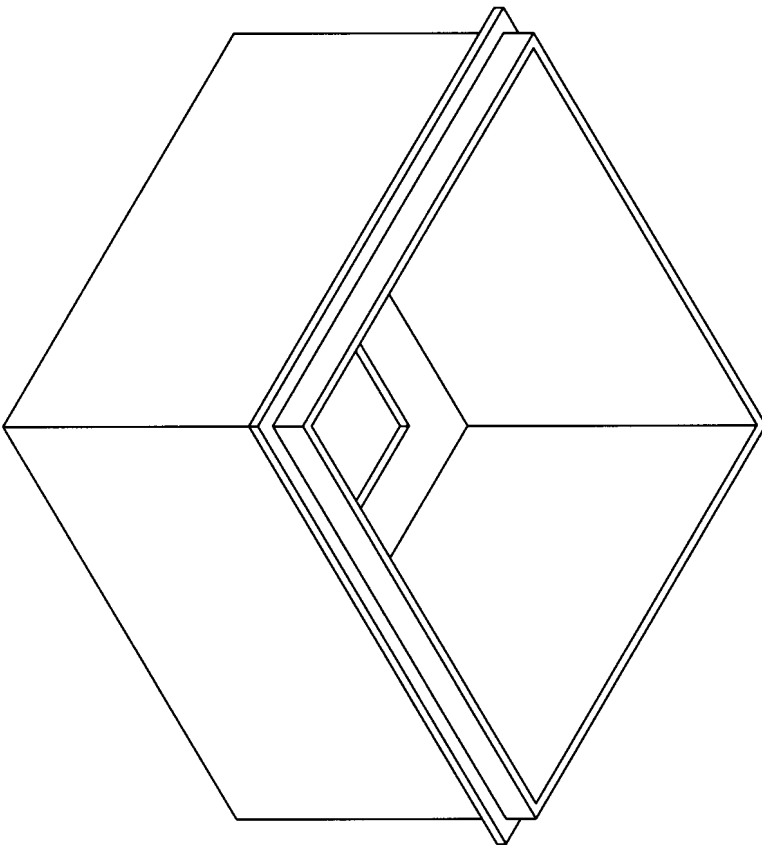

SECTION A-A

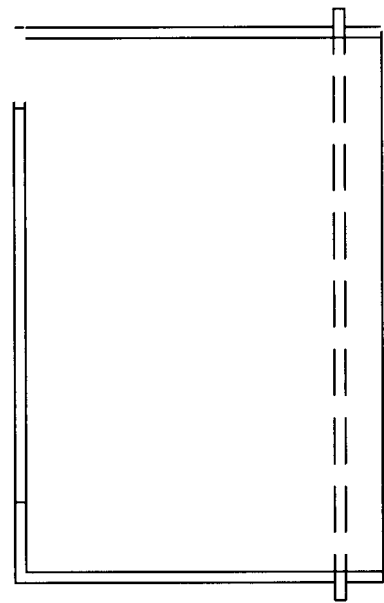

77,5

10/14

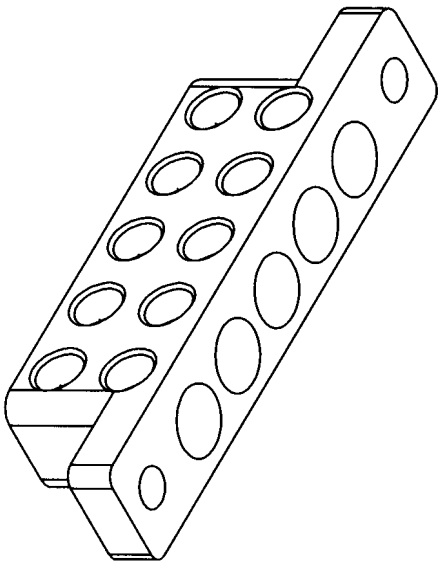

21

15

11,5

57

M7

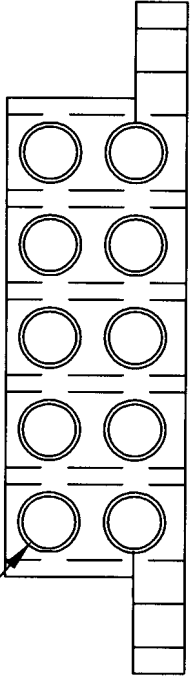

80

∅9

15

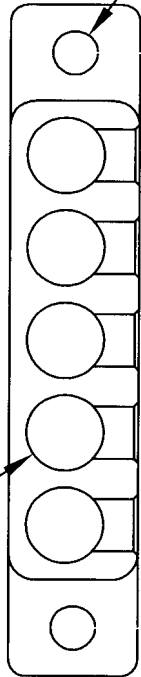

∅5,2

68,5

11/14

1,5

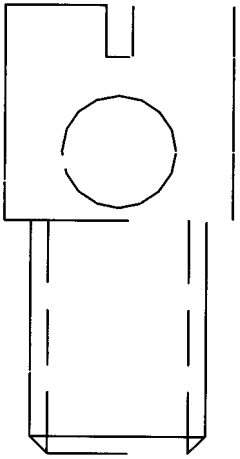

∅6,5

M10

3

8,5

12,5

26

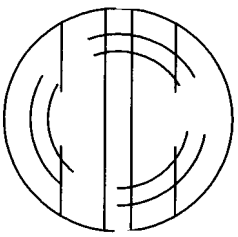

13

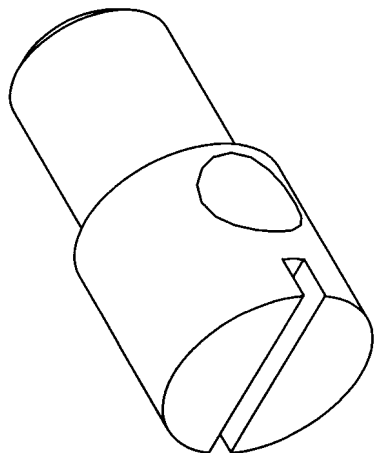

12/14

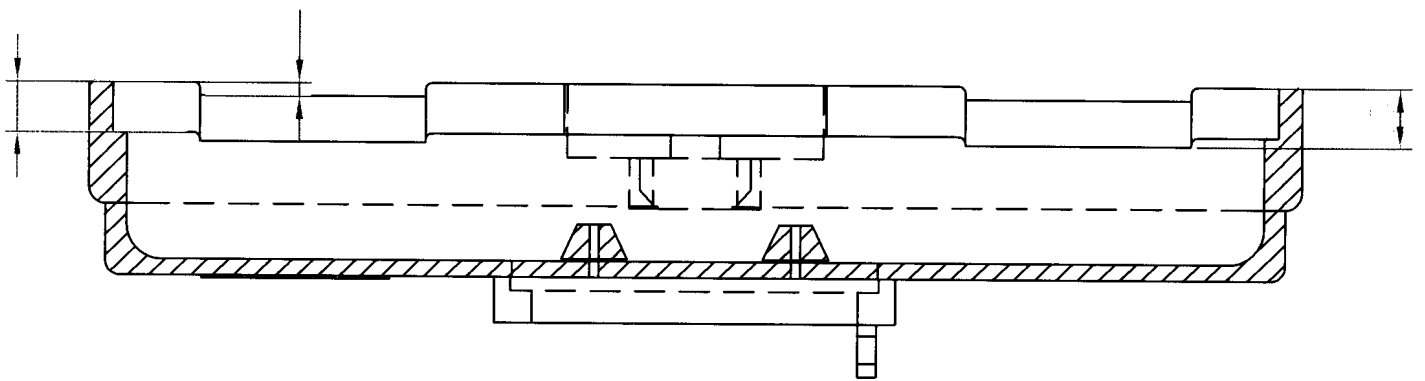

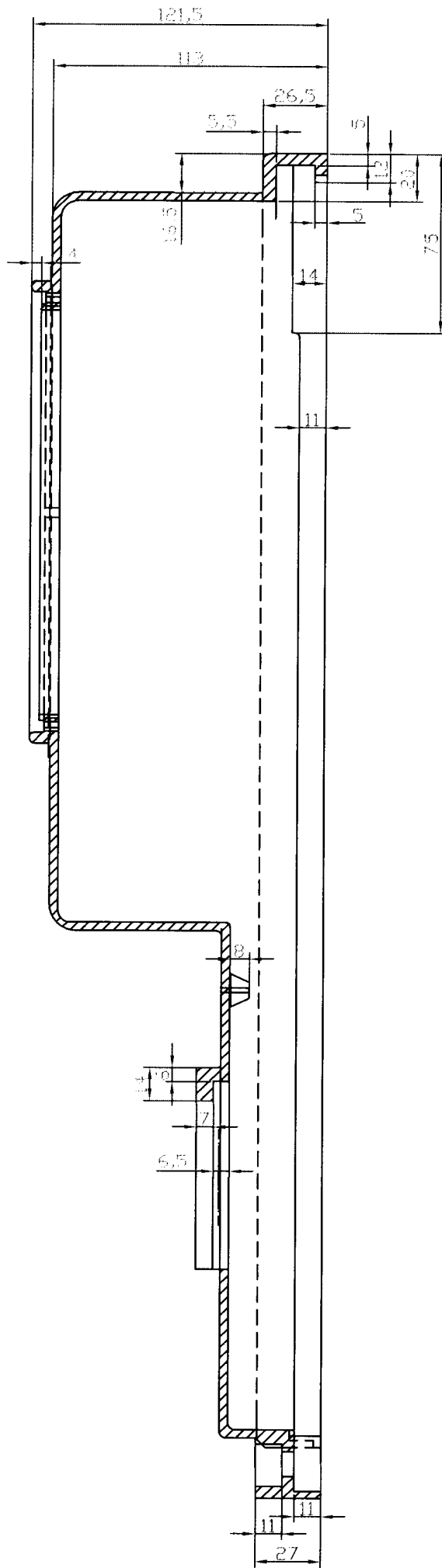

SECTION A-A

14/14